

**„8 mm is the benchmark!“**

The slim monitor of the BLADE 125 table with a 12.5" screen diagonal produces a crystal-clear FullHD image – and at a depth of just 8mm it is almost as sharp as a blade. Milled aluminium and black acrylic glass underscore the elegant and stylish lines of this unique table monitor. With the BLADE 125 table from ELEMENT ONE, design perfectly follows concept: It is an outstanding piece of technology to look at and touch.

**ELEMENT ONE**  
**Multimedia GmbH**  
Zum Murgdamm 5  
76456 Kuppenheim  
Deutschland

Fon: +49 (0)7222 96654 20  
Mail: [info@element-one.de](mailto:info@element-one.de)  
[www.element-one.de](http://www.element-one.de)

# BLADE 125 table



With its compact design, hi-res screen and elegant exterior, the BLADE 125 table is particularly suitable for

- ▶ Desks
- ▶ Podiums
- ▶ Reception areas
- ▶ Lounges
- ▶ Salesrooms and showrooms



SCOPE OF APPLICATION

# BLADE 125 table



TECHNICAL DATA

# Product Spezification

<b>Item Number</b>	425-125-4	<b>Resolution</b>	1920 x 1080 – Full HD (16:9)
<b>Type</b>	BLADE 125 table	<b>Pixel Size</b>	0.144mm x 0.144mm (176ppi)
<b>Feature</b>	12.5" FullHD Desktop Monitor with 15°/30° (alternatively) inclination	<b>Color Depth</b>	6-bit, 262,144 colors
<b>Material</b>	Anodized Aluminum, silver, 2 mm non-reflecting, coated protective glass	<b>Viewing Angle</b>	Horizontal 160° / Vertical 140°
<b>Dimensions</b>	380 x 215 x 129 mm	<b>Picture Area</b>	76.480(H) x 155.520(V)
<b>Mass</b>	ca. 1,6 kg	<b>Video Interface</b>	HDMI
<b>Monitor Specification</b>	FullHD 12.5" LED Backlit TFT, HDCP compliant, Active Matrix, Widescreen	<b>LED Life Span</b>	Up to 50,000 operating hours
<b>Format</b>	400 cd/m <sup>2</sup>	<b>Power Consumption</b>	15 W
<b>Contrast</b>	(typ.) 700:1	<b>Certificates</b>	CE, FCC
		<b>Warranty</b>	2 Years (see current general terms and conditions)

**Available Add-ons**

**Multi-Touch-Screen**

**Customized Anodization Color**

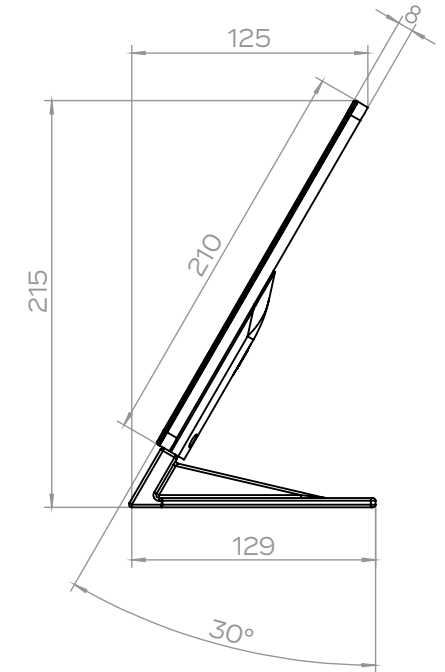
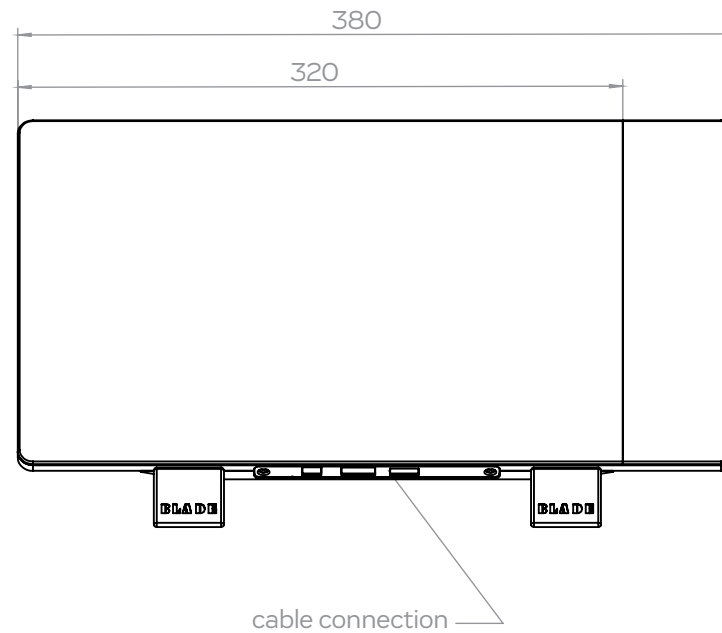
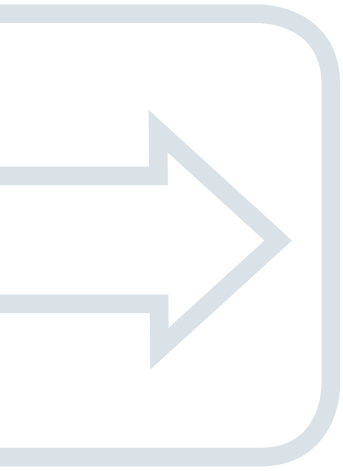

## TECHNICAL DATA

# Dimensions

We'd be delighted to offer our expertise in the planning and selection of the right solution for your needs. If required, we can send further technical drawings, detailed photographs, material samples and, of course, demo devices – perfect to handle and try out.

Simply call us on **+49 (0)7222 96654-20**  
Or send us an e-mail at: [info@element-one.de](mailto:info@element-one.de)