



IMPLEMENTATION CONCEPT

C SEED 301

C/SEED

THE UNFOLDING TV

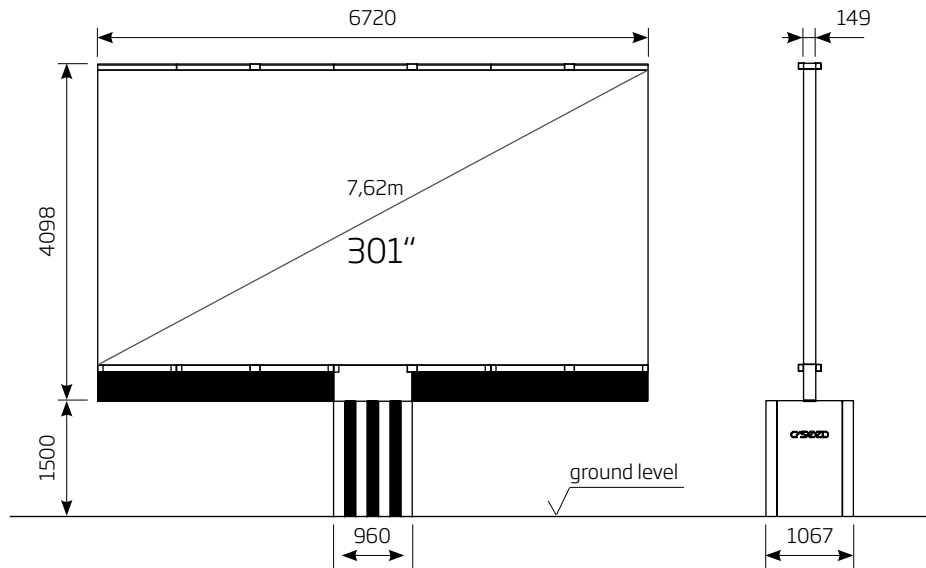

PHYSICAL DIMENSIONS TV

LED TV Size (diagonal)	inch/mm	301 / 7,645
LED TV Size (Width)	inch/mm	264.6 / 6,720
LED TV Size (Height)	inch/mm	153.5 / 3,898
Standard LED Screen (Depth)	inch/mm	5.9 / 149
LED TV Area	sq.ft./m ²	116 / 26.8
LED TV weight	kg	3,550
Elevation Device weight	kg	6,500

TV SYSTEM

Brightness	nits	4,000
Pixel Pitch	mm	1.90
Processing Depth	bit	16 per color
Color Spectrum	Colors	64 billion
Refresh Rate	Hz	3,840
Lifespan LED	h	100,000
Contrast Ratio		7,000:1
Color Temperature	K	6,500-10,000
Viewing Angle- Horizontal Vertical	degrees	160 160
Operating Temperature Range		°C: -20 to +45 °F: -4 to +113
Broadband speaker peak out	W	6 x 250
Broadband speaker frequency range		40 Hz - 22 kHz
Subwoofer peak out	W	1 x 1,200
Subwoofer frequency range		20 Hz - 200 Hz

INPUT | OUTPUT

Video Input	HDMI2.0/DP1.4
Serial In/Output	2 x USB
Audio Output	pre-amp, 9.2, independent sub
Network Connection	1 x RJ45

OPERATION

Power Supply LED Screen		3 x 400V+N+PE/63A/50-60Hz AC (3~)
Input Power max typical	W/m ²	880 230
Power Consumption max typical	kW	47 14

SPECIFIC FEATURES

Automatic TV Cover	9.2 AV-Receiver	Remote Control	4K LED HDR10+ Controller
TV Rotation Angle: 135° left & right		TV System Height Adjustable within 950mm	
Available in Black Matt Metallic or Greyaluminium Metallic or other colors on request			



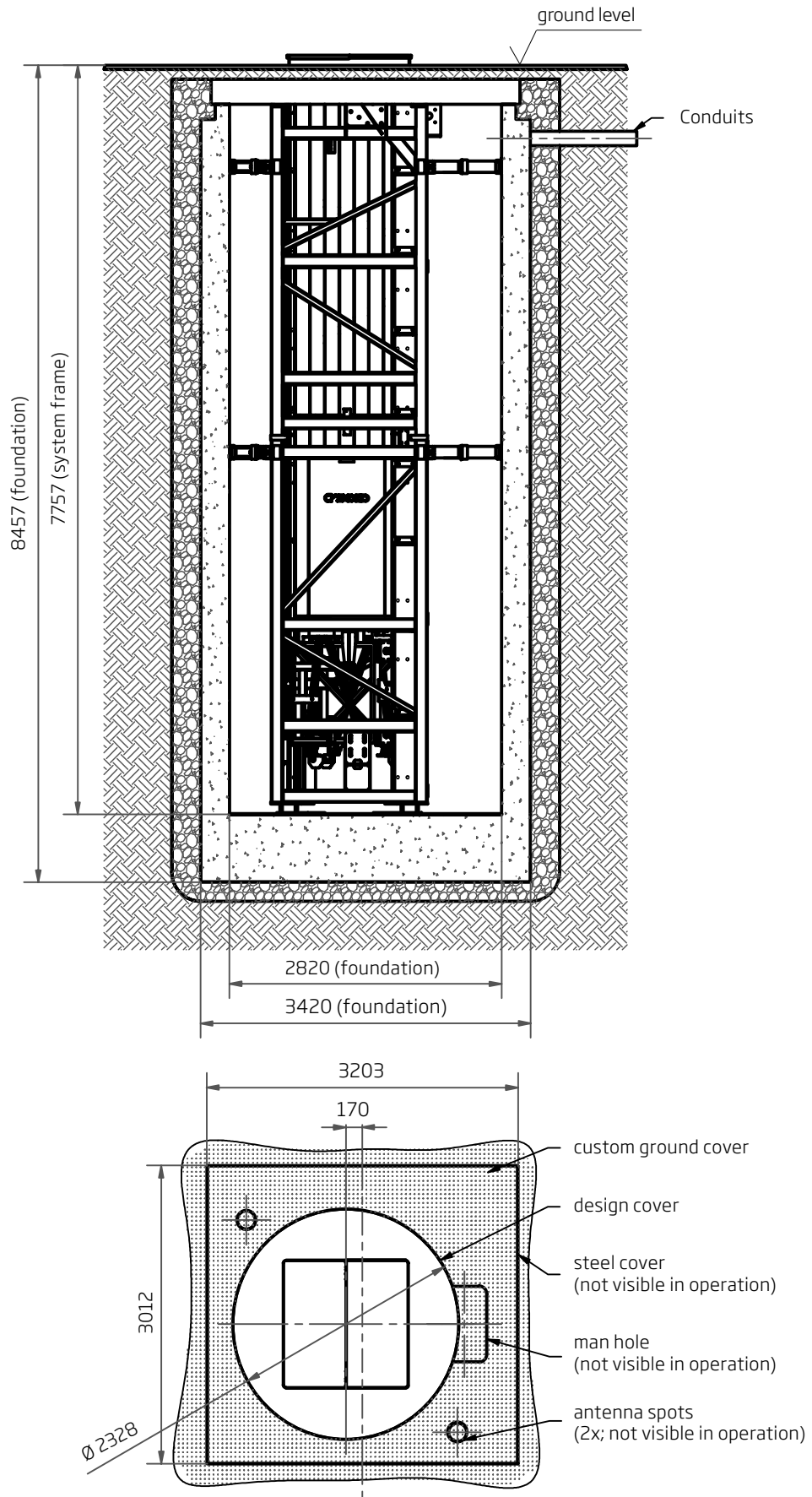

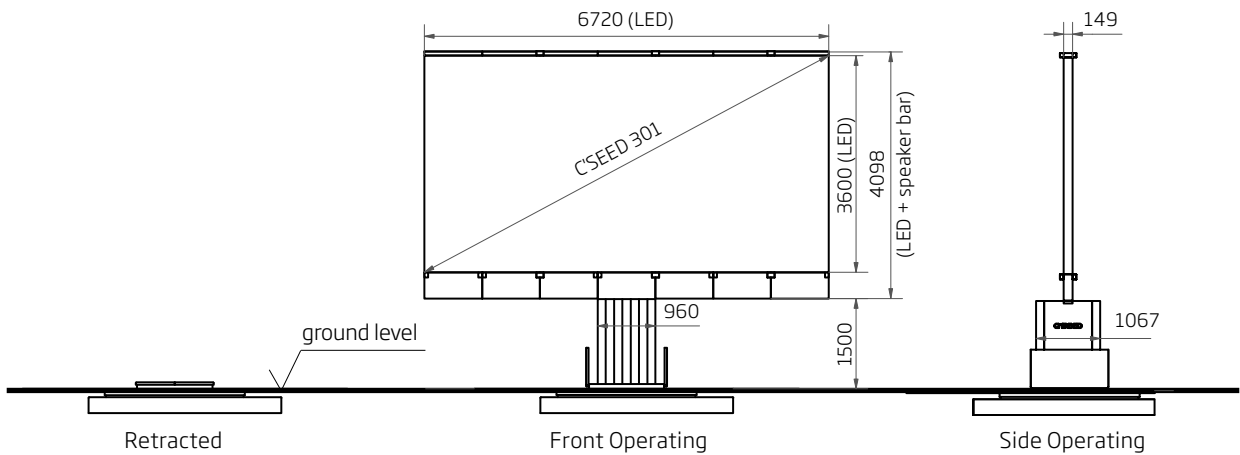
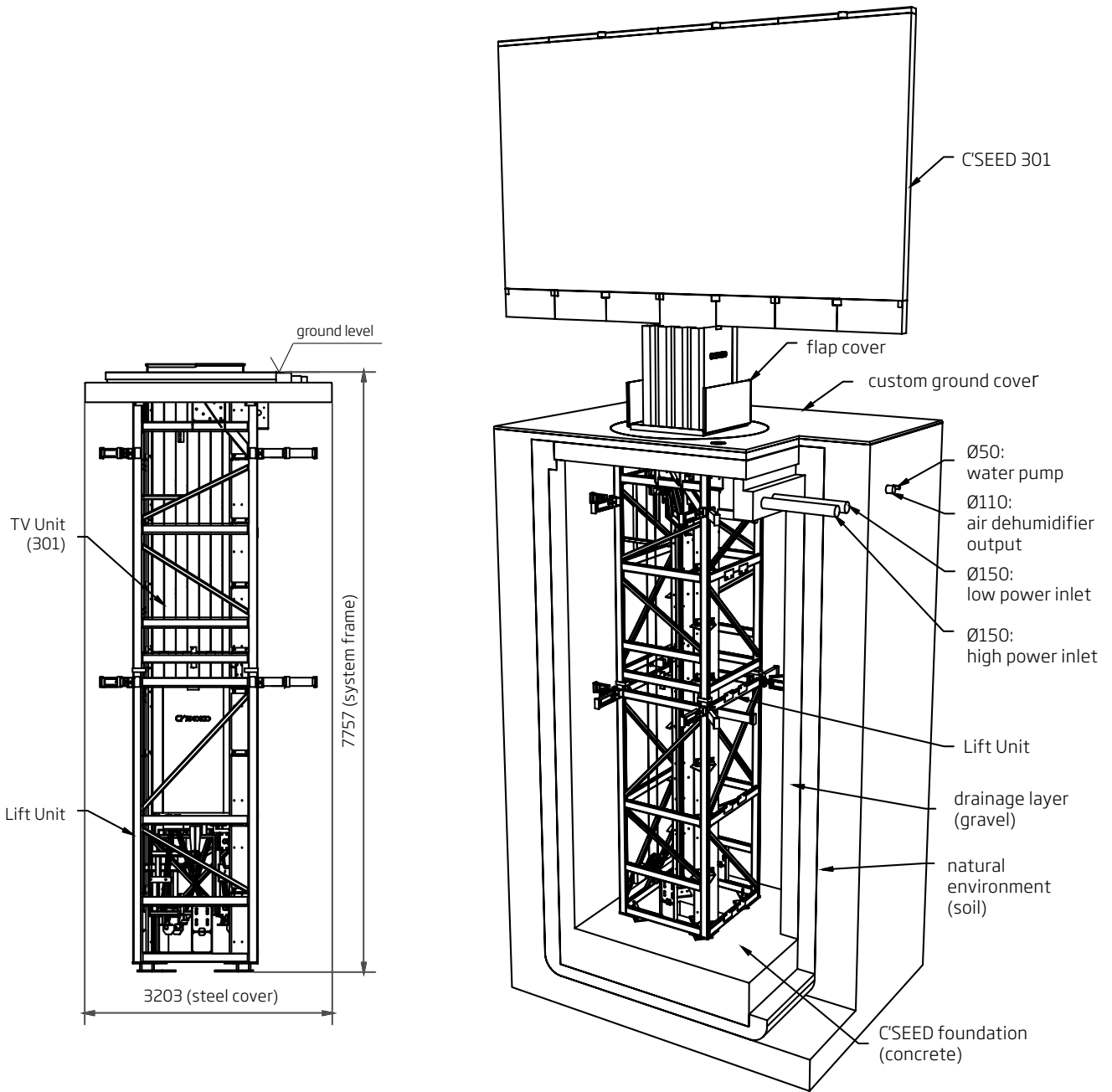

TV CONCRETE FOUNDATION

- 2820x2820x7757 mm | 111x111x306 inches | LxWxD
 - according to final TV concrete basin plan
- Earthing of the TV well (min. 3 times)
- Drainage - Natural drainage directly from the sump pit

EQUIPMENT CLOSE TO THE TV

- Emergency Stop Button
- Confirmation Panel
- HMI Touch panel for wired system control
- Weather Station Location near the TV
- Dehumidifier device (provided by owner of the venue)

TECHNICAL ROOM

max. 100m | 320 feet to TV system

- Requested Output: 3x400V+N+PE | 63A | 50-60Hz AC (3~)

Transformer | Power Converter (if requested output not as above, provided by owner of the venue)

- Requested Output: 3x400V+N+PE | 63A | 50-60Hz AC (3~)

UPS | uninterruptible power supply

- 3x400V+N+PE
- 320x700x840 mm | 12.6x27.6x33.1 inches | WxHxD
- Ventilation on backside (300 mm | 12 inches free space must be reserved)
- High power transformer needed (provided by owner of the venue)

Control Cabinet

- 800x1100x300 mm | 32x44x12 inches | WxHxD
- Feed cable with 5 pins or 4 pins plus additional earthing
- Connector on left side (200mm | 8 inches free space must be reserved)
- Power protection with a "fault-current circuit breaker AC/DC sensitive and electric frequency converter capable"

AV-Rack

- AV-Rack with 32RU - 600x1600x800 mm | 23.7x63x31.5 inches | WxHxD
- SAT | Video | TV signals to be connected via HDMI inputs
- Internet connection as of beginning of installation (permanent!)

CABLING DUCTS AND CONDUITS

- 1 tube with diameter 150 mm | 6 inches (not less)
 - Located between electricity cabinet and TV-System (high power connection)
- 1 Tube with diameter 150 mm | 6 inches (not less)
 - Located between AV rack and TV-System (data cables from MMS)
- 1 Tube with diameter 40mm | 1 ½ inches (not less)
 - Located between weather station and control cabinet (weather station data)
- 1 Tube with diameter 40 mm | 1½ inches (not less)
 - Located between Control Cabinet and Confirmation Panel
- 1 Tube with diameter 40 mm | 1½ inches (not less)
 - Located between Control Cabinet and Antenna
- 1 Tube with diameter 40 mm | 1½ inches (not less)
 - Only if Control Cabinet and AV-Rack are not in same room

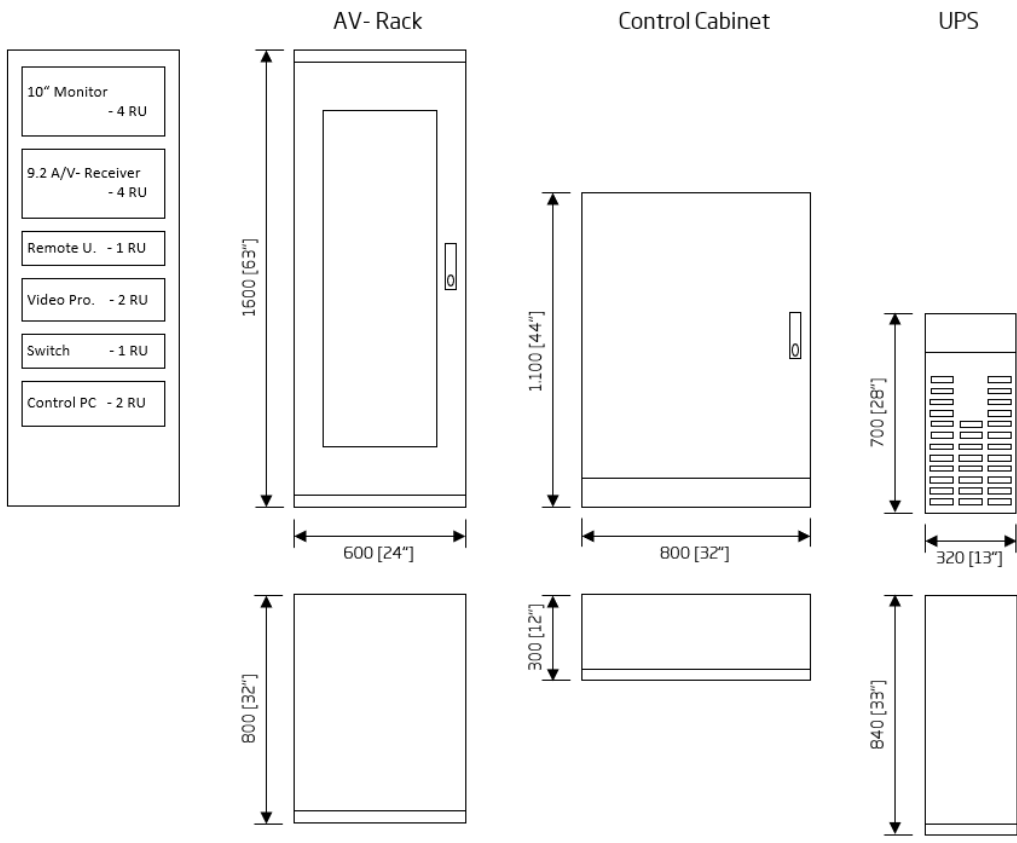
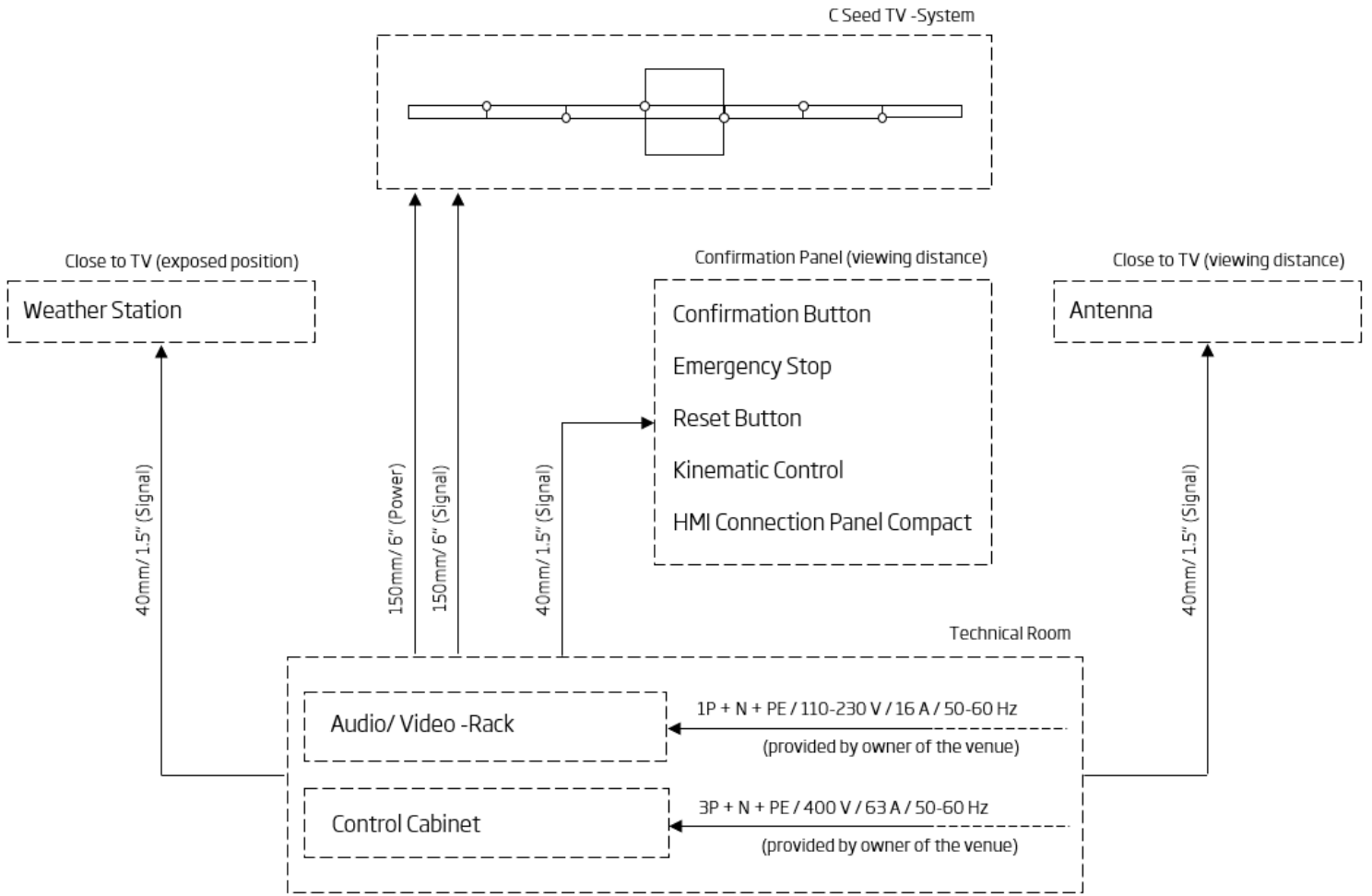

SERVICES PROVIDED BY AND AT THE EXPENSES OF THE OWNER OF THE VENUE

- Power Supply: 3x400V+N+PE I 63A I 50-60Hz AC (3~)
- Internet connection at the AV - Rack as of beginning of the installation
- WIFI I WLAN at the venue as of beginning of the installation
- Access for heavy duty excavator, crane and trucks to TV well
- Excavation for the construction of the TV concrete basin according to ground-structure
- Waterproof construction of the TV shaft according to C SEED plans
- Cabling ducts & conduits for TV system according C SEED electrical conduits plan (project specific)
- Cables and cable installation according to C SEED electrical cable plan (project specific)
- Dehumidifier device, sump pump, conduits & cabling for it and connections to power supply and drainage
- Sat I video I TV signals at the AV-Rack
- Crane on site approximately 20 hours in total (min. 6 tons & 10 meters of height)
- Connecting Power Supply by local electrician
- Electrical test protocol according to international standards of all cables must be provided to C SEED prior installation

SERVICES PROVIDED BY C SEED

- Site visit - meeting with construction company, civil engineer etc.
- Standard plan for construction of the TV well for local civil engineer
- Project related engineering package
- Coordination with local electrician
- Coordination with local sat I video I TV professional
- Implementation, programming & testing of the C SEED TV
- TCP/IP control protocol for home automation
- Operation training for technical staff of the venue
- Handover & Acceptance Protocol

Contacts

Owner representative _____

Construction company of the venue _____

C SEED Project manager _____

Vers.: 5.2/HP/25.07.23

"The information and specification contained in the implementation concept are information purpose only and are subject to change without prior notice"

www.cseed.com