



# IMPLEMENTATION CONCEPT

C SEED N1  
OUTDOOR  
165

C/SEED

THE UNFOLDING TV

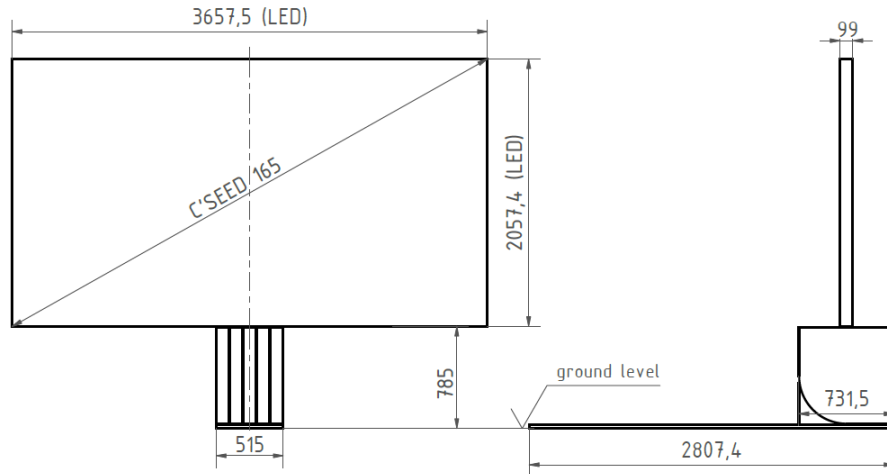
**PHYSICAL DIMENSIONS TV**

LED TV size (diagonal)	inch/mm	165 / 4196
LED TV size (width)	inch/mm	144 / 3657
LED TV size (height)	inch/mm	81 / 2057.4
Standard LED screen (depth)	inch/mm	3.9 / 99
LED TV area	sq.ft./m <sup>2</sup>	81 / 7.53
Total system weight		900kg / 2000lb

**TV SYSTEM**

Brightness	nits	4,000
Pixel pitch	mm	1.9
Processing depth	bit	16 per color
Color spectrum	colors	64 billion
Refresh rate	Hz	3,840
Lifespan LED	h	100,000
Contrast ratio		7,000:1
Color temperature	K	6,500 - 10,000
Viewing angle- horizontal   vertical	degrees	160   160
Operating temperature range		C°: -20 to +45   F°: -4 to +113
Broadband speaker peak out	W	2 x 100
Broadband speaker frequency range	Hz	60 - 22,000
Subwoofer peak out	W	1 x 250
Broadband speaker frequency range	Hz	40 - 200

**INPUT / OUTPUT**

Video input	HDMI2.0/DP1.4
Serial in/output	2 x USB
Audio output	pre-amp, 9.2, independent sub
Network connection	1 x RJ45

**OPERATION**

Power supply LED screen	Standard	3 x 400V+N+PE/16A/50-60Hz
	High-Leg-Delta	3 x 240V+PE/30A/50-60Hz
	Single-Phase/Split-Phase	240V/120V+PE/60A/50-60Hz
Input power max   typical	W/m <sup>2</sup>	650   225
Power consumption max   typical	kW	4.9   1.7

**SPECIFIC FEATURES**

2.1 Sound System	TV-Rotation options: 180° left (counterclockwise) or 90° left & right
4K UHD Video-Controller	Remote Control
	9.2 AV-Receiver



**ACCORDING TO EXACT POSITIONS OF CABLING CONDUITS:**

- C SEED N1 to AV-Rack in Technical room (max. 100 m | 320 feet)

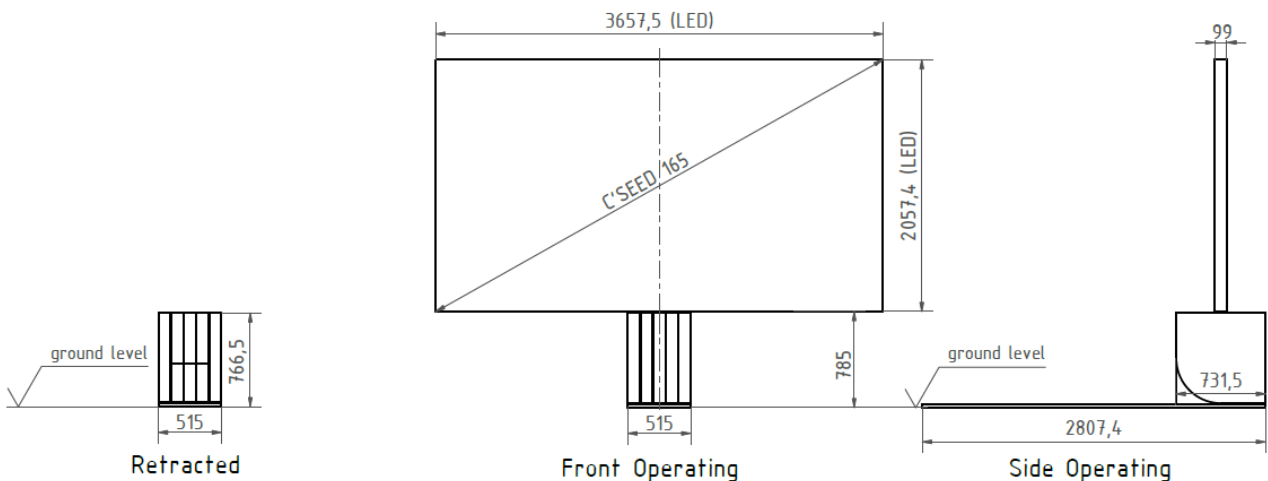
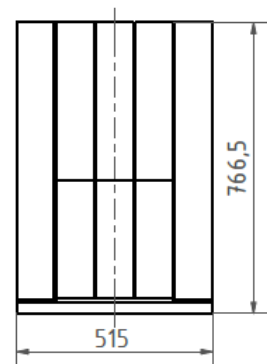
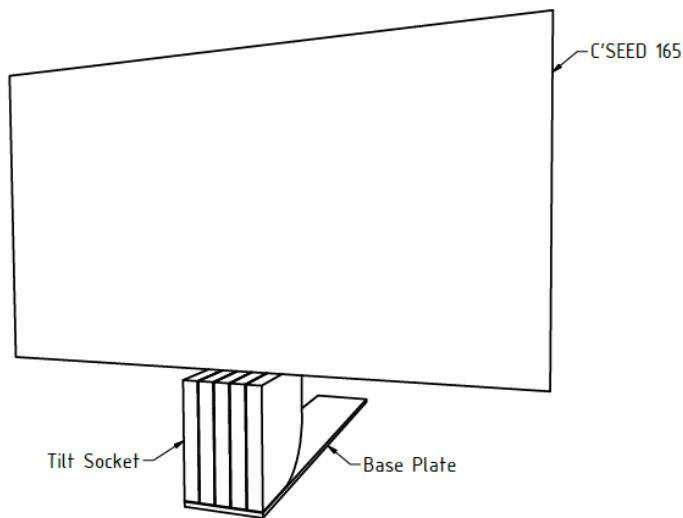
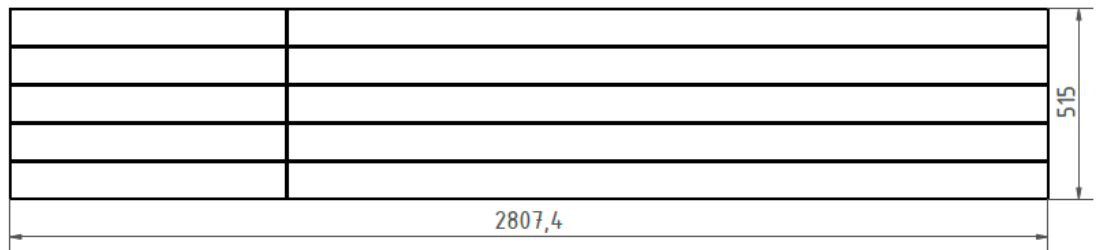
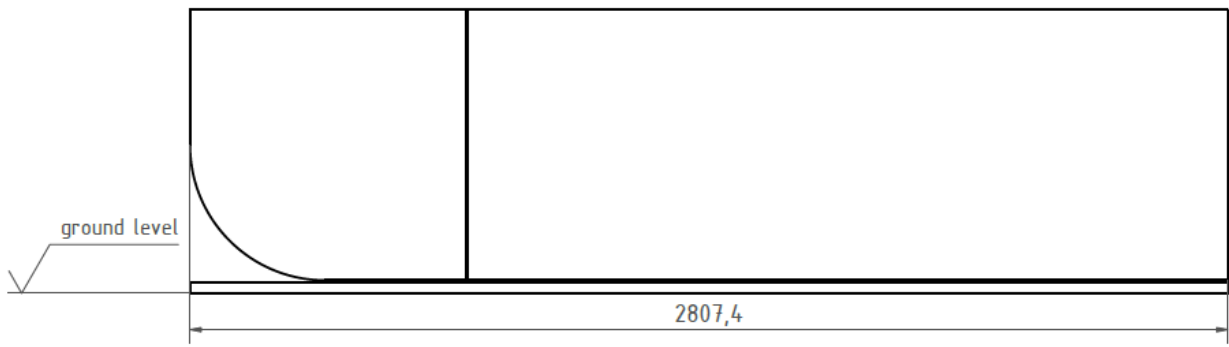



## Earthing

---

- Earthing of the TV well (min. 3 times)

## TECHNICAL ROOM

---

max. 100m | 320 feet to TV system

## AV-Rack (will be supplied by C SEED)

---

- AV-Rack with 42RU - 600x2053x800 mm | 24x81x32 inches | WxHxD
- Feed cable with 5 pins or 4 pins plus additional earthing
- Power protection with a "fault-current circuit breaker AC/DC sensitive and electric frequency converter capable"
- SAT | Video | TV signals to be connected via HDMI inputs
- Internet connection as of beginning of installation (permanent!)

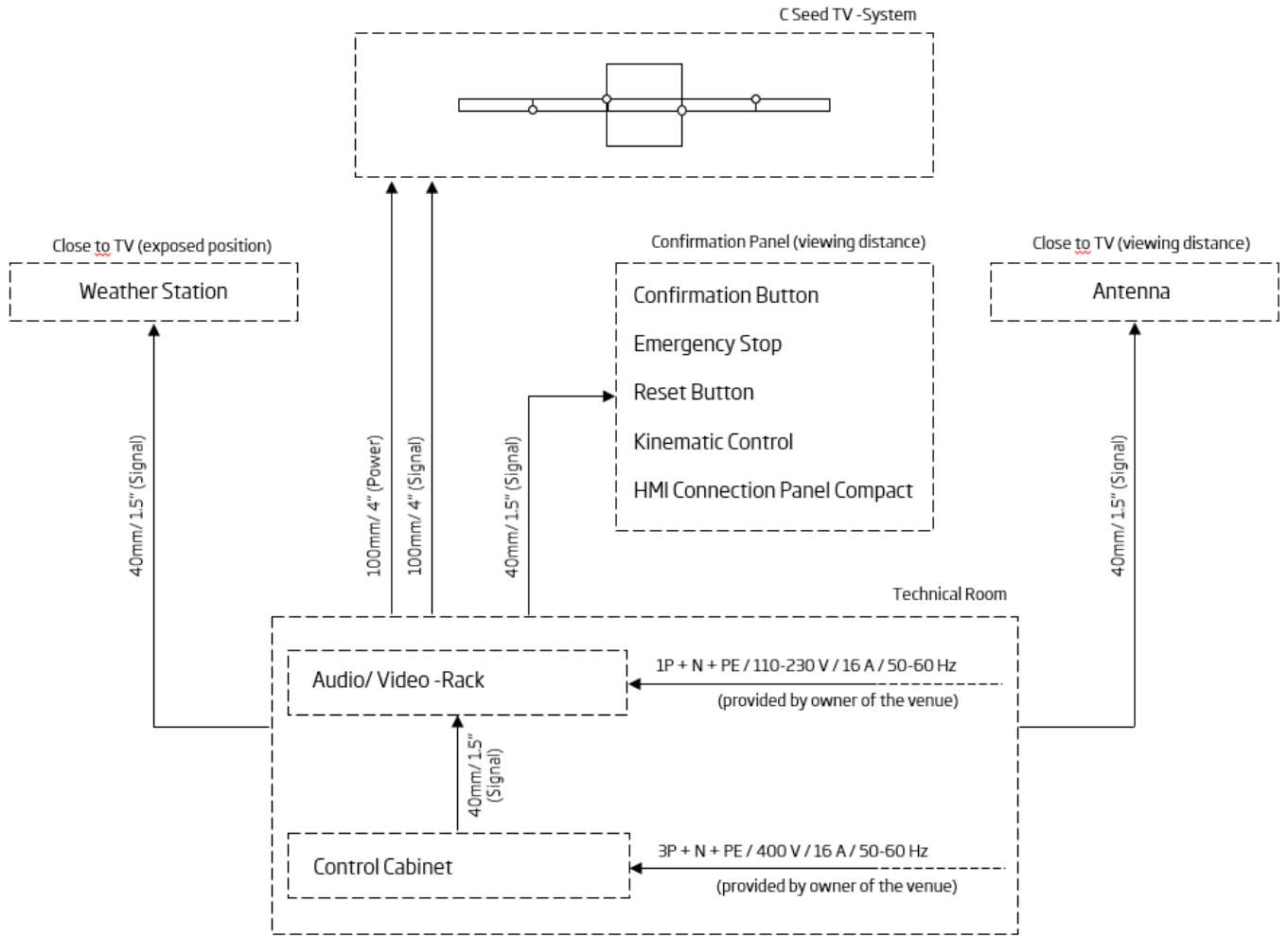

## AV- Rack

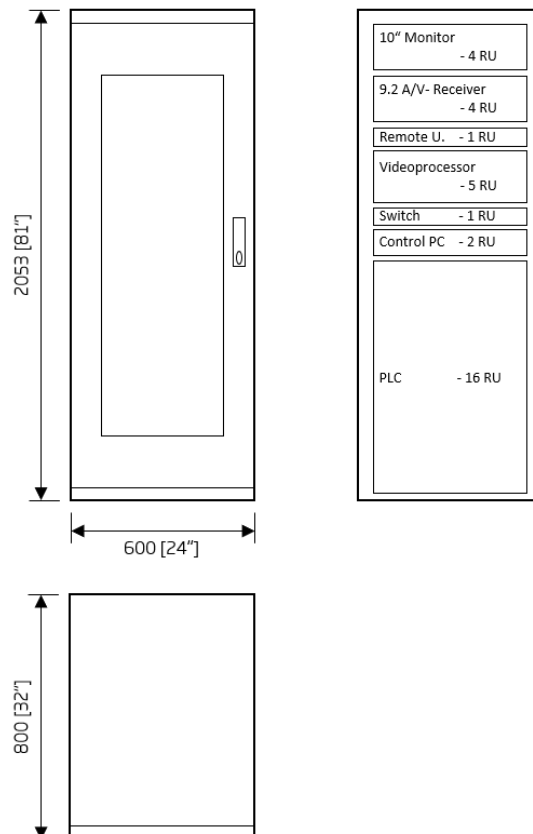

**SERVICES PROVIDED BY AND  
AT THE EXPENSES OF THE OWNER OF THE VENUE**

---

- Power Supply:                      Standard      3 x 400V+N+PE/16A/50-60Hz  
   High-Leg-Delta\*      3 x 240V+PE/30A/50-60Hz  
   Single-Phase/Split-Phase\*\*      240V/120V+PE/60A/50-60Hz
- \*/\*\*Transformer | \*\*Phase Converter (provided by owner of the venue)
- Requested Output: 3x400V+N+PE | 16A | 50-60Hz AC (3~)
- \*/\*\*Transformer: TEMCo Euro-Plus Transformer TT1003 - 15 kVA  
<https://temcoindustrial.com/temco-euro-plus-trade-transformer-tt1003-15-kva/>
- \*\*Phase Converter: 10HP 240V Digital Phase Converter - Phase Perfect® <https://www.phaseperfect.com/original/240-volt/pt010/>
- Internet connection at the AV - Rack as of beginning of the installation
- WIFI | WLAN at the venue as of beginning of the installation
- Cabling ducts & conduits for TV system according C SEED electrical conduits plan (project specific)
- Cables and cable installation according to C SEED electrical cable plan (project specific)
- Sat | video | TV signals at the AV-Rack
- Connecting Power Supply by local electrician
- Electrical test protocol according to international standards of all cables must be provided to C SEED prior installation

**SERVICES PROVIDED BY C SEED**

---

- Site visit - meeting with construction company, civil engineer etc.
- Project related engineering package
- Coordination with local electrician
- Coordination with local sat | video | TV professional
- Implementation, programming & testing of the C SEED N1 165
- TCP/IP control protocol for home automation
- Operation training for technical staff of the venue
- Handover & Acceptance Protocol

**Contacts**

---

Owner representative \_\_\_\_\_

Construction company of the venue \_\_\_\_\_

C SEED Project manager \_\_\_\_\_

Vers.: 1.1/HP/25.07.23

“The information and specification contained in the implementation concept are information purpose only and are subject to change without prior notice”