

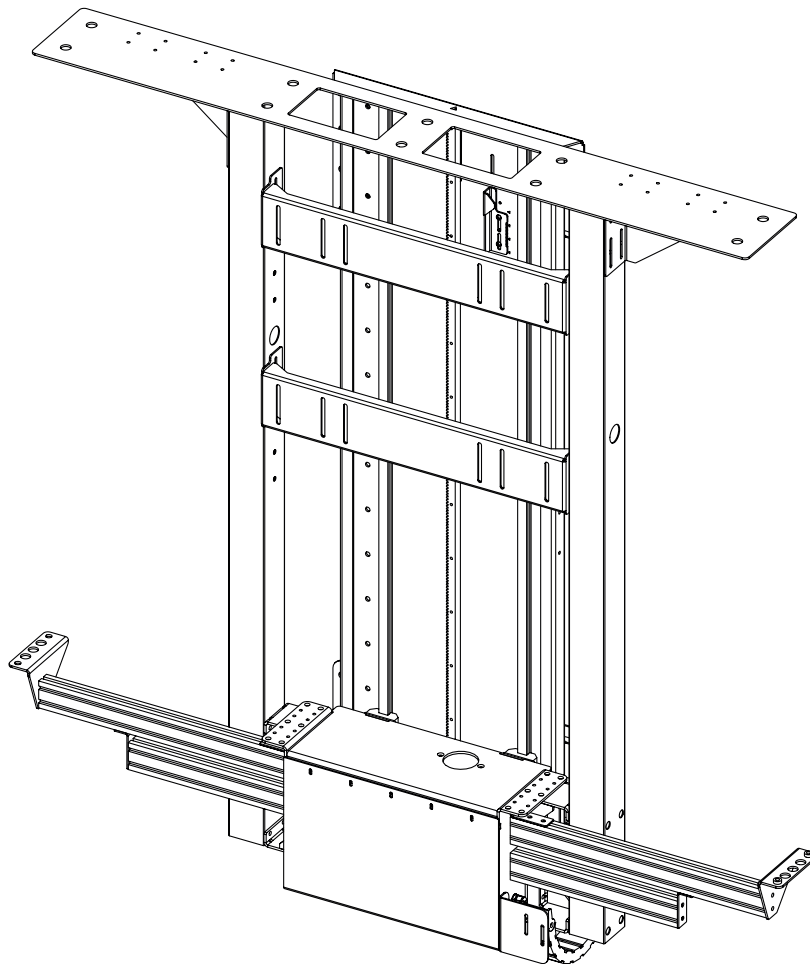

future automation

# LSH-MO

MARINE OUTDOOR LIFT SYSTEM HEAVY



## INSTALLATION INSTRUCTIONS

ISSUE 001



# SAFETY DISCLAIMER

## IMPORTANT SAFETY INSTRUCTIONS BELOW

**WARNING:** Failure to provide adequate structural strengthening, prior to installation can result in serious personal injury or damage to the equipment. It is the installer's responsibility to ensure the structure to which the component is affixed can support four times the weight of the component and any additional apparatus mounted to the component.

**WARNING:** Do not exceed the weight capacity for this product as listed below. This can result in serious personal injury or damage to the equipment. It is the installer's responsibility to ensure that the total combined weight of all attached components does not exceed that of the maximum figure stated.

**WARNING:** Risk of death or serious injury may occur when children climb on audio and/or video equipment or furniture. A remote control or toys placed on the furnishing may encourage a child to climb on the furnishing and as a result the furnishing may tip over on to the child.

**WARNING:** Risk of death or serious injury may occur. Relocating audio and/or video equipment to furniture not specifically designed to support audio and/or video equipment may result in death or serious injury due to the furnishing collapsing or over turning onto a child or adult.



Only for use with equipment weighing **220LBS (100KG) OR LESS.**

Use with heavier screens may lead to instability causing tip over or failure resulting in death or serious injury.

Bracket Suitable for Residential and Commercial Use.

### ADDITIONAL WARNINGS:

1. Keep all documentation/instructions after fitting.
2. Read all technical instructions fully before installation and use. It is the installer's responsibility to ensure that all documentation is passed on to the end user and read fully before operation.
3. Do not use near water or outdoors unless the product has been specifically designed to do so.
4. Protect any cables or cords being used near this bracket from being walked on or pinched to prevent damage and risk of injury.
5. Use this product only for its intended purpose as described in the product instructions and only use attachments/accessories specified by the manufacturer.
6. Do not operate the product if it is damaged in any way, liquid has been spilled or objects have fallen into the apparatus, the apparatus has been exposed to rain or moisture, does not operate normally, or has been dropped. Contact the original installer/manufacturer to arrange repair or return.

### WARNING - To reduce the risk of burns, fire, electric shock, or injury to persons:

1. Clean only with a dry cloth and always unplug any electrical items being used in conjunction with this product before cleaning.

Future Sound & Vision trading as Future Automation intend to make this and all documentation as accurate as possible. However, Future Automation makes no claim that the information contained herein covers all details, conditions or variations, nor does it provide for every possible contingency in connection with the installation or use of this product. The information contained in this document is subject to change without prior notice or obligation of any kind. Future Automation makes no representation of warranty, expressed or implied, regarding the information contained herein. Future Automation assumes no responsibility for accuracy, completeness or sufficiency of the information contained in this document.

# PRODUCT WARRANTY & RISK ASSESSMENT

## WARRANTY INFORMATION

**WARNING - The warranty offered for this product shall be annulled if the product is used improperly or in a way that is in breach of our Terms of Service.**

Future Automation provides warranty for the mechanism you purchased for the period of **24 months** from the date of purchase, provided that it isn't used for unintended purposes.

Under the warranty, Future Automation aims to either solve the issue remotely (via telephone or email support) or if the mechanism requires a part, arrange a visit to your premises by a Future Automation approved engineer or send replacement items where appropriate.

Warranty repairs will be carried out as quickly as possible, but subject to parts availability. This warranty period is respectively extended for the period of a repair.

A malfunctioning product must be cleaned and placed into suitable packaging to protect against transit damage before organising delivery to a repair workshop.

All the complaints about defects must be submitted to the vendor/installer that sold this product, rather than directly to the manufacturer.

Any part of your system that needs to be replaced during a warranty repair becomes the property of Future Automation.

### **The warranty does not cover the following:**

- Damages resulting from improper product use or maintenance.
- Repairs carried out by unauthorized persons.
- Natural wear and tear during operation.
- Damages caused by the buyer.
- Accidental damages caused by a customer or damages caused as a result of careless attitude or usage, or damages caused by natural disasters (natural phenomena).
- Any electrical, or other environmental work external to your Future Automation mechanism including power cuts, surges etc.
- Additional items not supplied by Future Automation although they may have been supplied together by the retailer
- Any 3rd party software products controlling your mechanism
- Any transfer of ownership. Warranty is provided only to the initial purchaser.
- Compensation for loss of use of the product, and consequential loss of any kind.

A separate Safety and Servicing Information document is provided with these instructions (additional copies can be found at [www.futureautomation.co.uk/safety](http://www.futureautomation.co.uk/safety)), and this document **MUST** be filled out by the approved Future Automation Dealer who is installing the product. This Warranty Sheet must be held by the end user for the duration of the products life and will be referred to during servicing or warranty queries.

The Safety and Servicing Information document also contains two Service History Forms that must be filled in by the approved Future Automation dealer who is performing the first required yearly service of this product.

**One copy of the Service History Form must be held by the customer (along with the Warranty Sheet) and a duplicate copy must be held by the approved Future Automation dealer that performed the service. Missing and/or mismatching documents may delay or invalidate warranty claims.**

Additional Service History Forms can be found on the Future Automation website for further yearly services.

## RISK ASSESSMENT INFORMATION

It is the installer's responsibility to perform a risk assessment of installed products. Future Automation can provide guidelines to installers/dealer about what should be included in a risk assessment, but due to the individual nuances of each location/site, Future Automation cannot provide a full list of areas to risk assess.

For full risk assessment and safety information please view our Safety and Servicing guide available at [www.futureautomation.net/safety](http://www.futureautomation.net/safety)

# GUIDE CONTENTS

SAFETY DISCLAIMER .....	<b>1</b>
PRODUCT WARRANTY & RISK ASSESSMENT .....	<b>2</b>
GUIDE CONTENTS .....	<b>3</b>
PACKAGE CONTENTS .....	<b>4</b>
INITIAL TESTING .....	<b>5</b>
LSH-MO FITTING .....	<b>6</b>
BASE PANEL FITTING .....	<b>7</b>
FURTHER MECHANISM FIXINGS .....	<b>9</b>
LSH TOP CAP FITTING .....	<b>10</b>
SWITCH ADJUSTMENTS .....	<b>11</b>
GENERAL CONTROL .....	<b>12</b>
INFRARED (IR) .....	<b>13</b>
CONTACT CLOSURE .....	<b>14</b>
RS232 CONTROL .....	<b>15</b>

# PACKAGE CONTENTS

## 1 - LSH-MO MECHANISM

- 1.1 - LIFTING BEAM
- 1.2 - SCREEN MOUNT
- 1.3 - BASE MOUNT & SUPPORT
- 1.4 - TOP CAP MOUNT

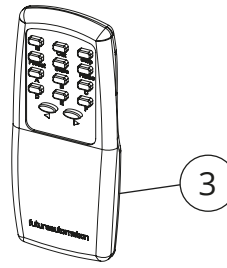

## 2 - CONTROL BOX

- 2.1 - CONTROL BOX
- 2.2 - 3M CABLE LOOM
- 2.3 - MECHANISM CABLE CONNECTORS
- 2.3 - INFRA-REF CONTROL LEAD

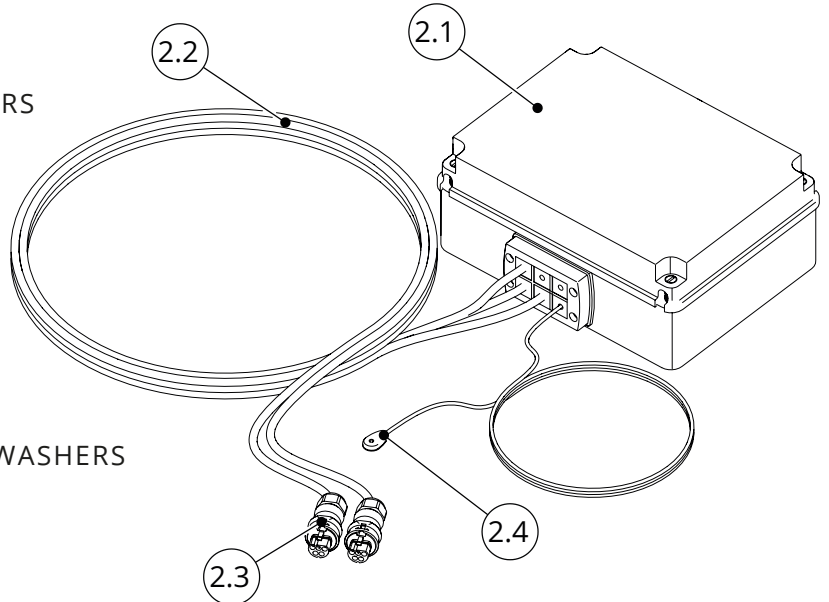

## 3 - INFRARED (IR) REMOTE CONTROL

### ITEMS NOT SHOWN ON PAGE

#### LSH-MO ACCESSORY PACK:

- X2 AAA BATTERIES
- MAINS POWER LEAD
- CAT5 LEAD WITH RJ45 CONNECTOR
- MULTI-PACK OF NUTS, BOLTS AND WASHERS
- EMERGENCY STOP KEY

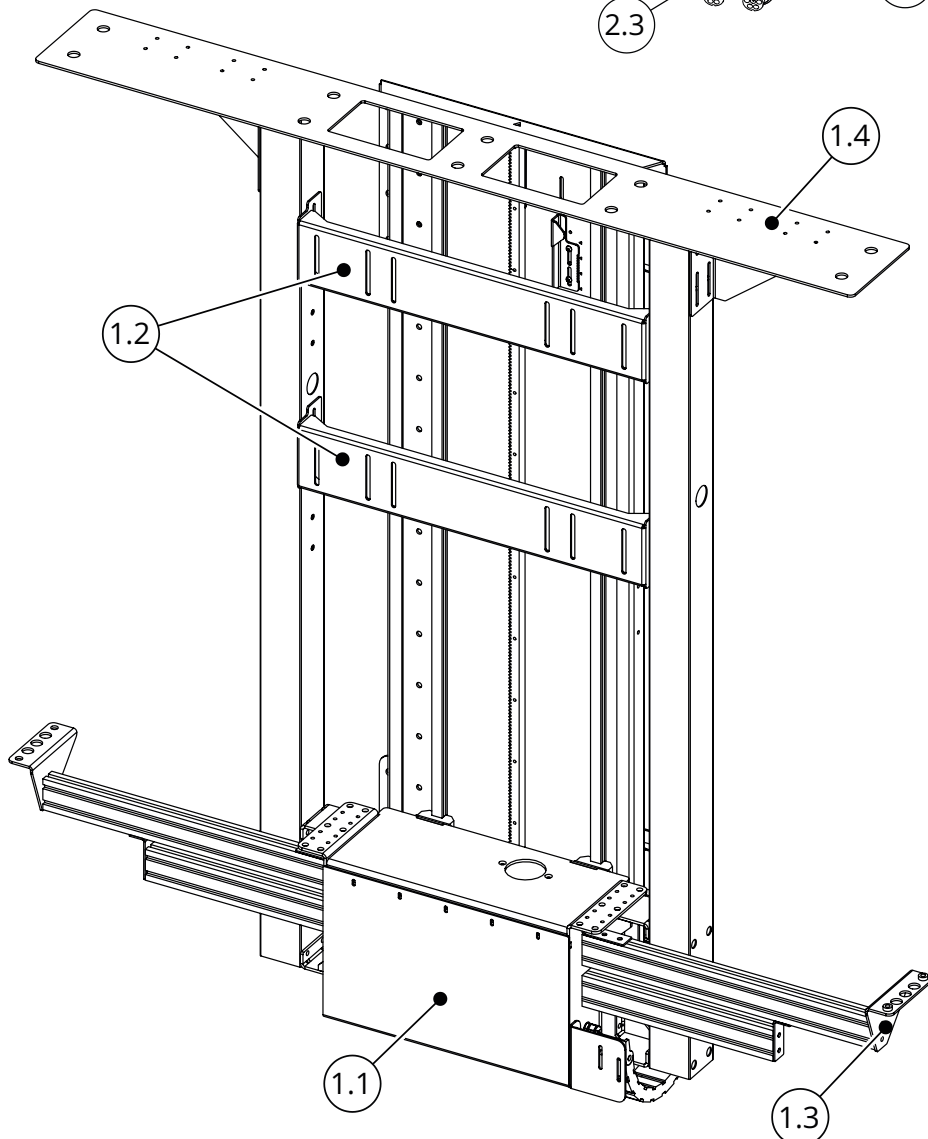

# INITIAL TESTING

Before installing the LSH-MO mechanism:

- Remove all red cable ties.
- Check there is no damage to any part of the LSH-MO mechanism, control board, or wiring.
- Check all internal and external mechanism wiring is secure.



**WARNING: THE LSH-MO MECHANISM DOES NOT HAVE AN ANTI-JAM CAPABILITY. THE MOTOR DRIVE SYSTEM WILL CONTINUE TO MOVE UNTIL A LIMIT SWITCH IS CONTACTED. KEEP HANDS AND ANY OBJECTS CLEAR OF THE MECHANISM DURING OPERATION TO REDUCE RISK OF DAMAGE OR INJURY.**

## 1

Connect the control board to the LSH-MO using the mechanism cable connectors at the end of the cable looms. Ensure that the IR lead and the emergency stop are the control box is secure.

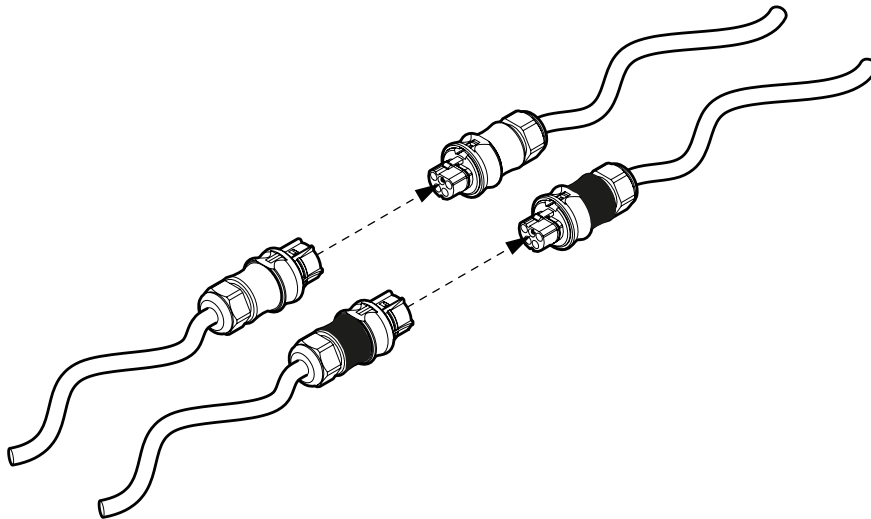

## 2

Familiarise yourself with the mechanism.

Pressing 'OUT' on the IR remote will raise the lifting beam.

Pressing 'IN' will lower the lifting beam.

Pressing 'HOME' will take the mechanism to an 'OUT' position.

# LSH-MO FITTING

- 1 Place the LSH centrally in the pit. Ensure the top of the mechanism is 12mm (1/2") below the underside of the floor. Use blocks or a plinth to raise the mechanism if necessary.

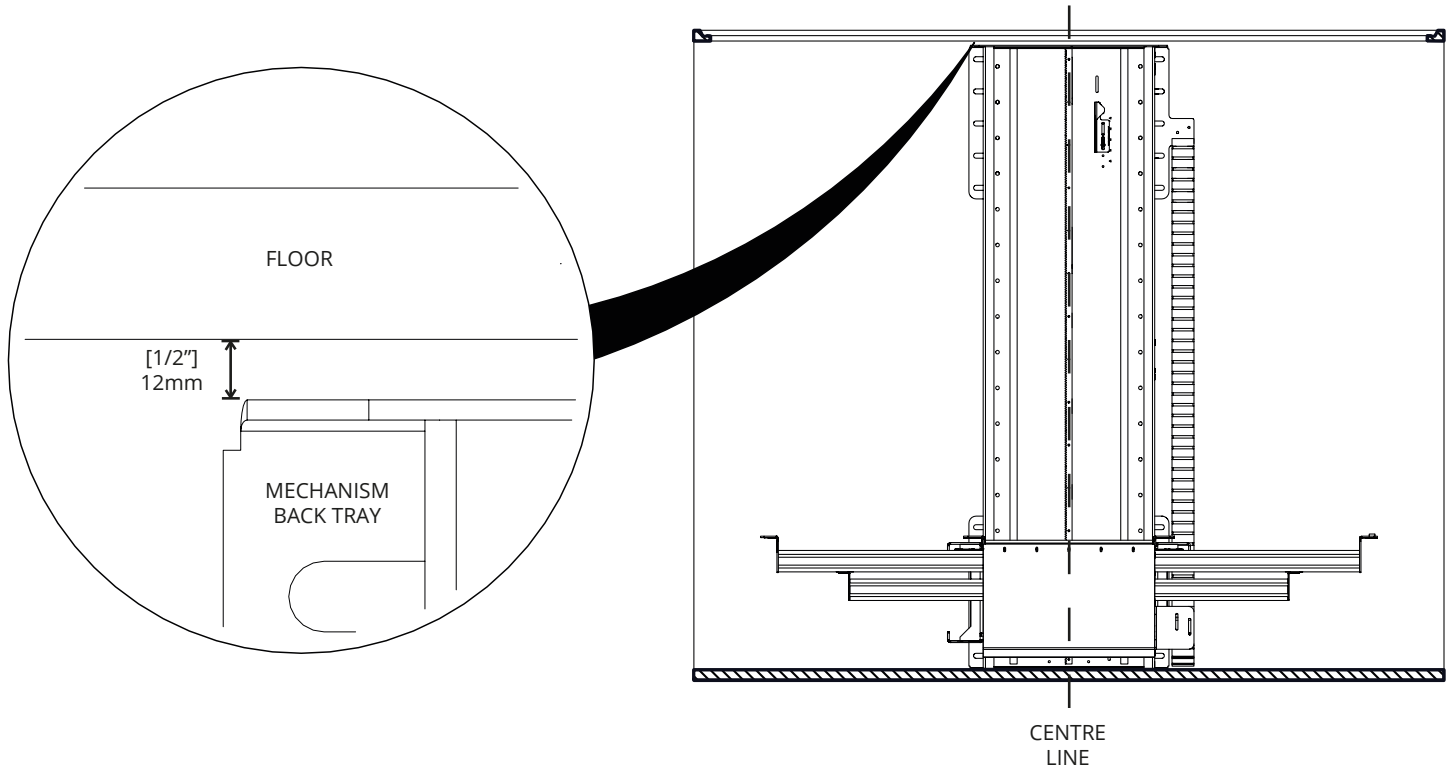

- 2 Once in the correct position, bolt the mechanism to the pit wall. Using only the top mount slots, further fixings will be fitted later in the insulation.

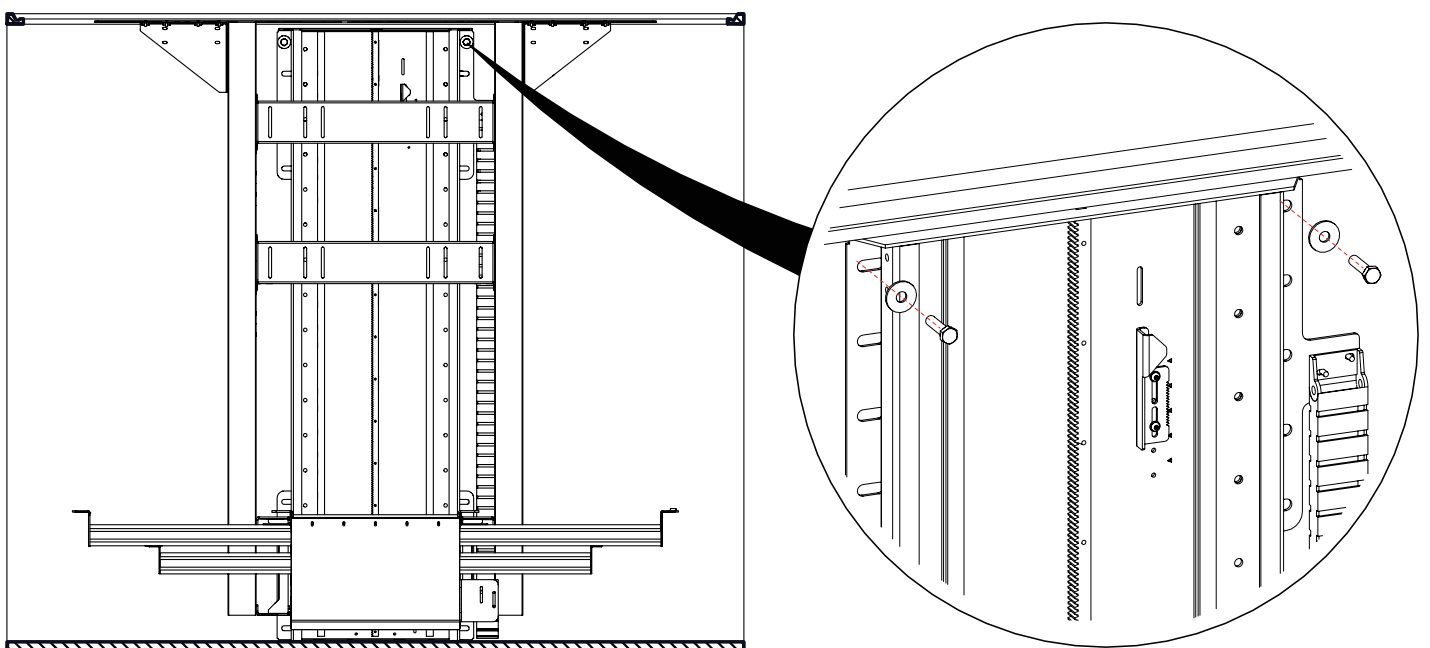



# BASE PANEL FITTING

**1** The base panel requires a cut out detail as shown below.

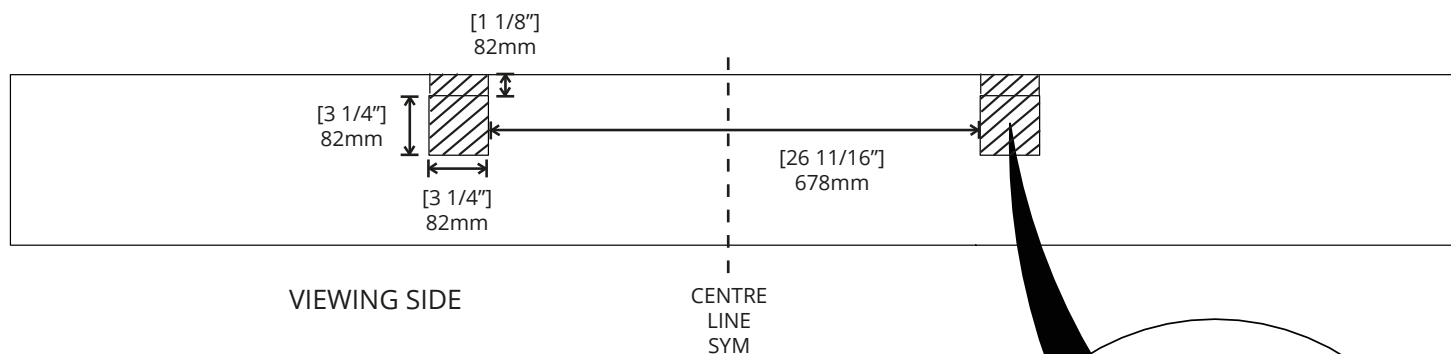

**2** Place the base panel onto the lifting beam and re-insert the base cut out pieces.

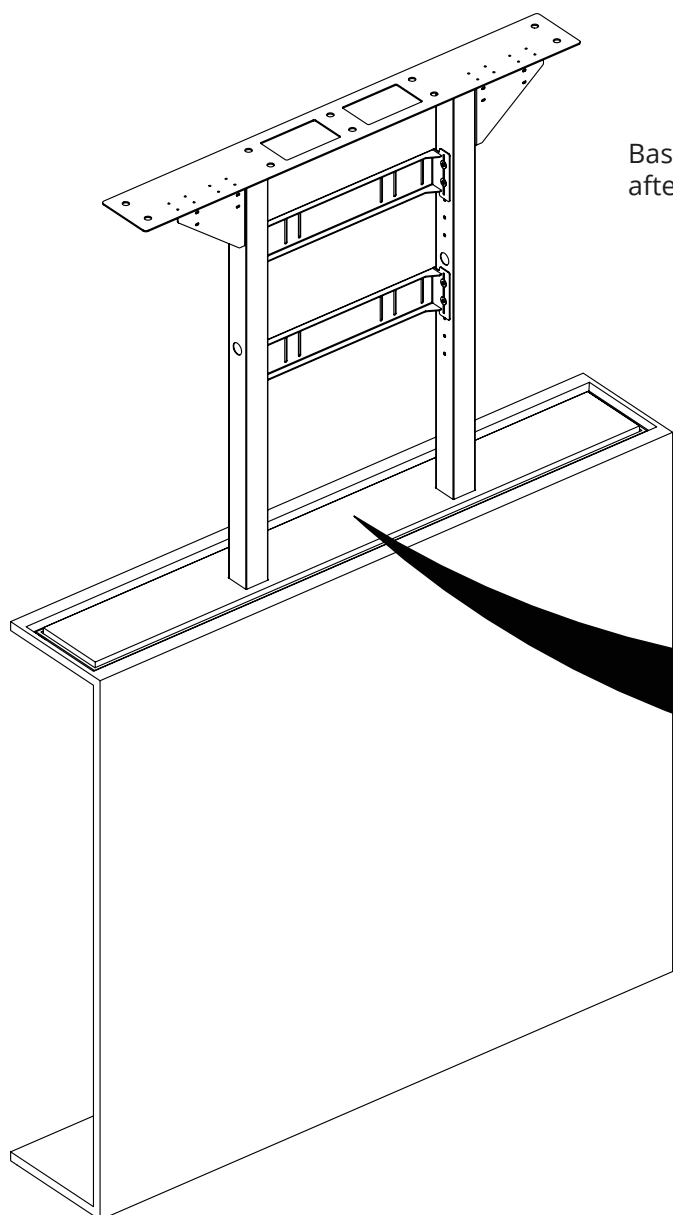

Base piece to be re-inserted after base panel installation.

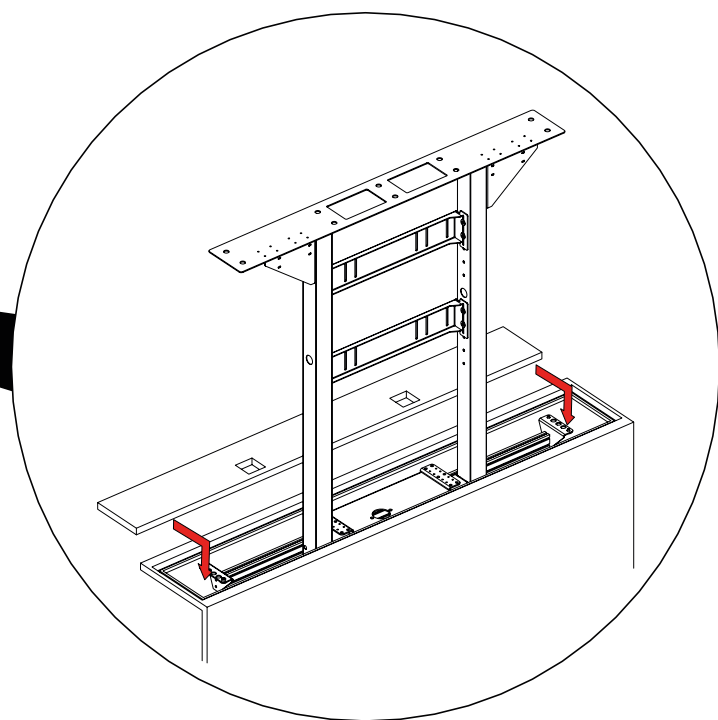
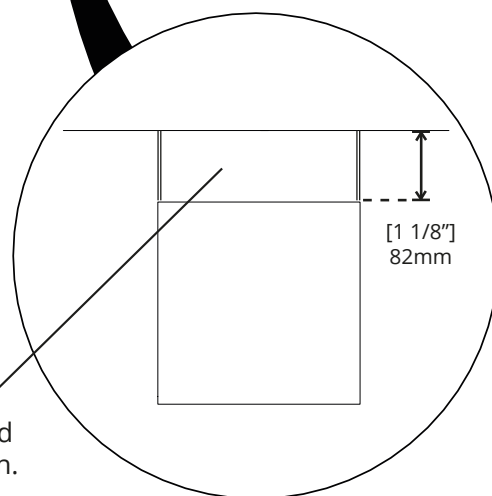

# BASE PANEL FITTING CONT.

# 3

Ensure that the base panel is central to the aperture and has a minimum of 5mm clearance. Loosen the existing fixings and shift the mechanism if necessary.

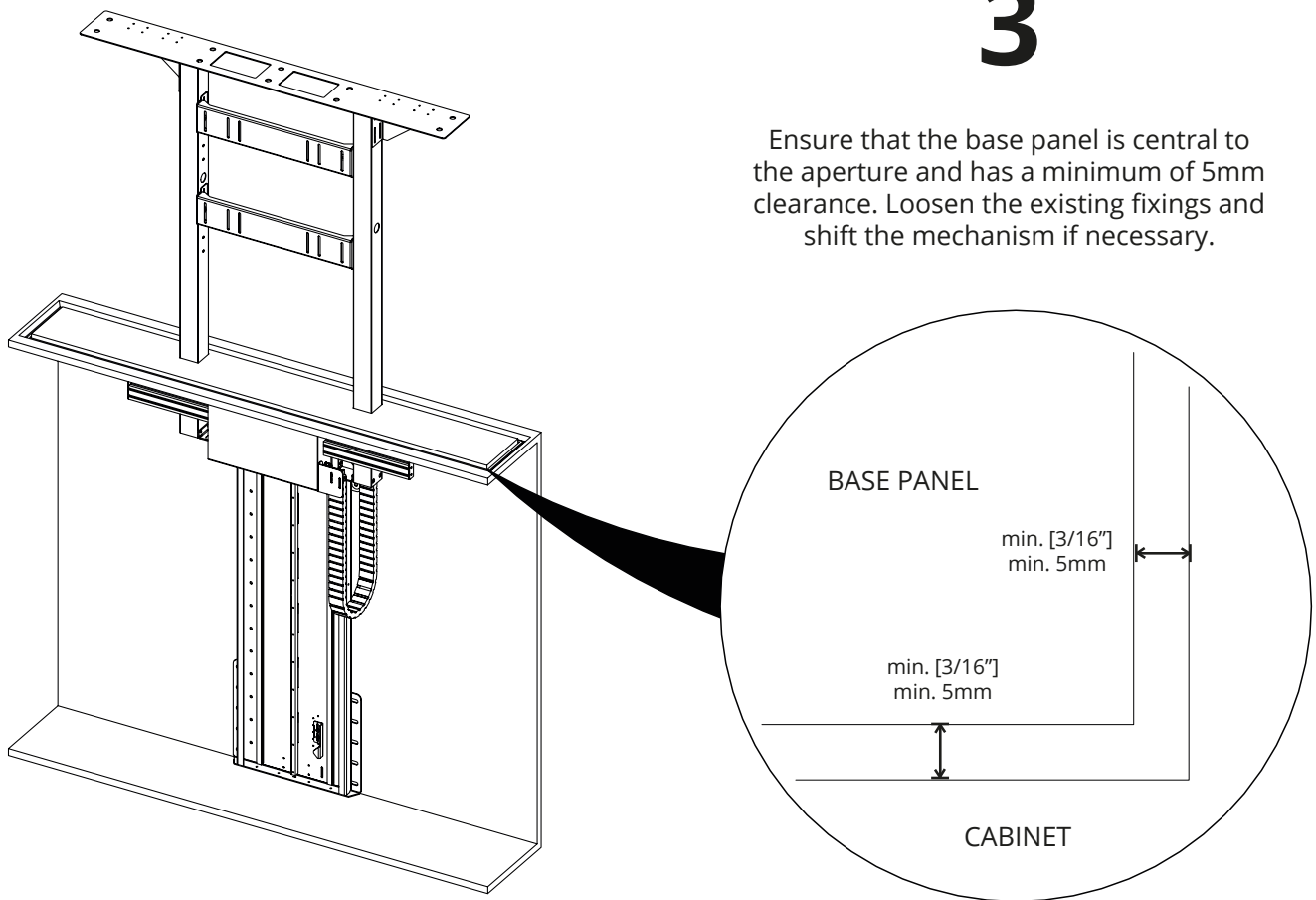

# 4

Using the appropriate fixings, secure the base panel to the mechanism on both sides.

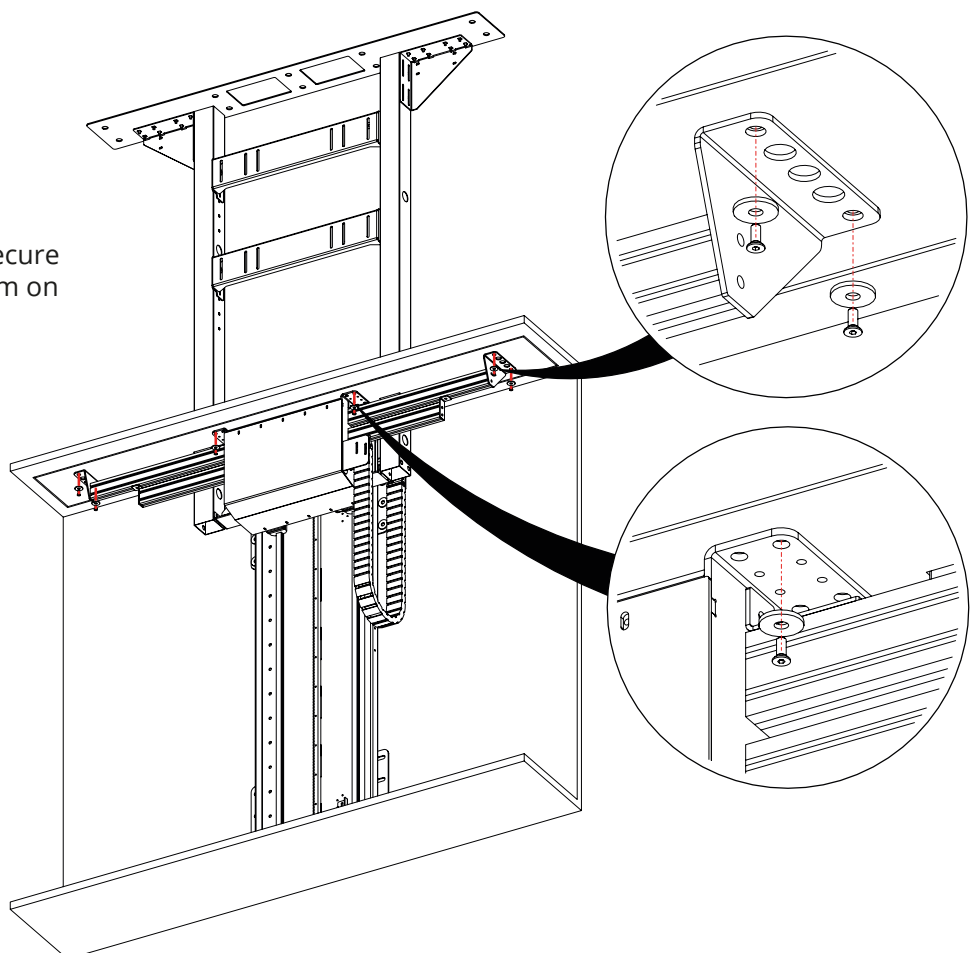

# FURTHER MECHANISM FIXINGS

- 1 With the base panel confirmed to fit through the aperture. Add further bolts at the top and bottom of the mechanism as shown below. Securing the mechanism to the back wall.

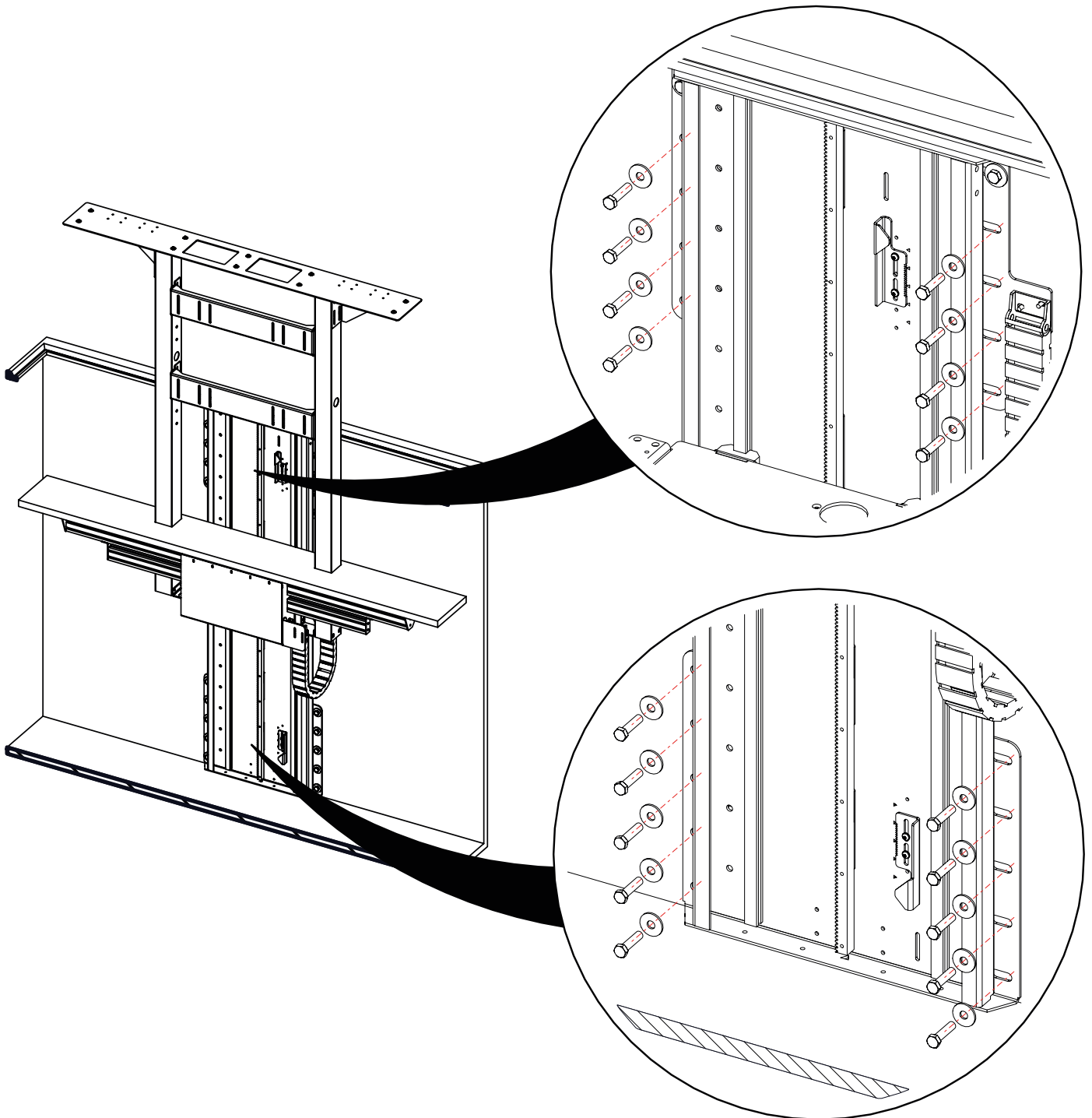

# LSH TOP CAP FITTING

- 1** Secure the top cap to the top cap mount using the appropriate fixings.

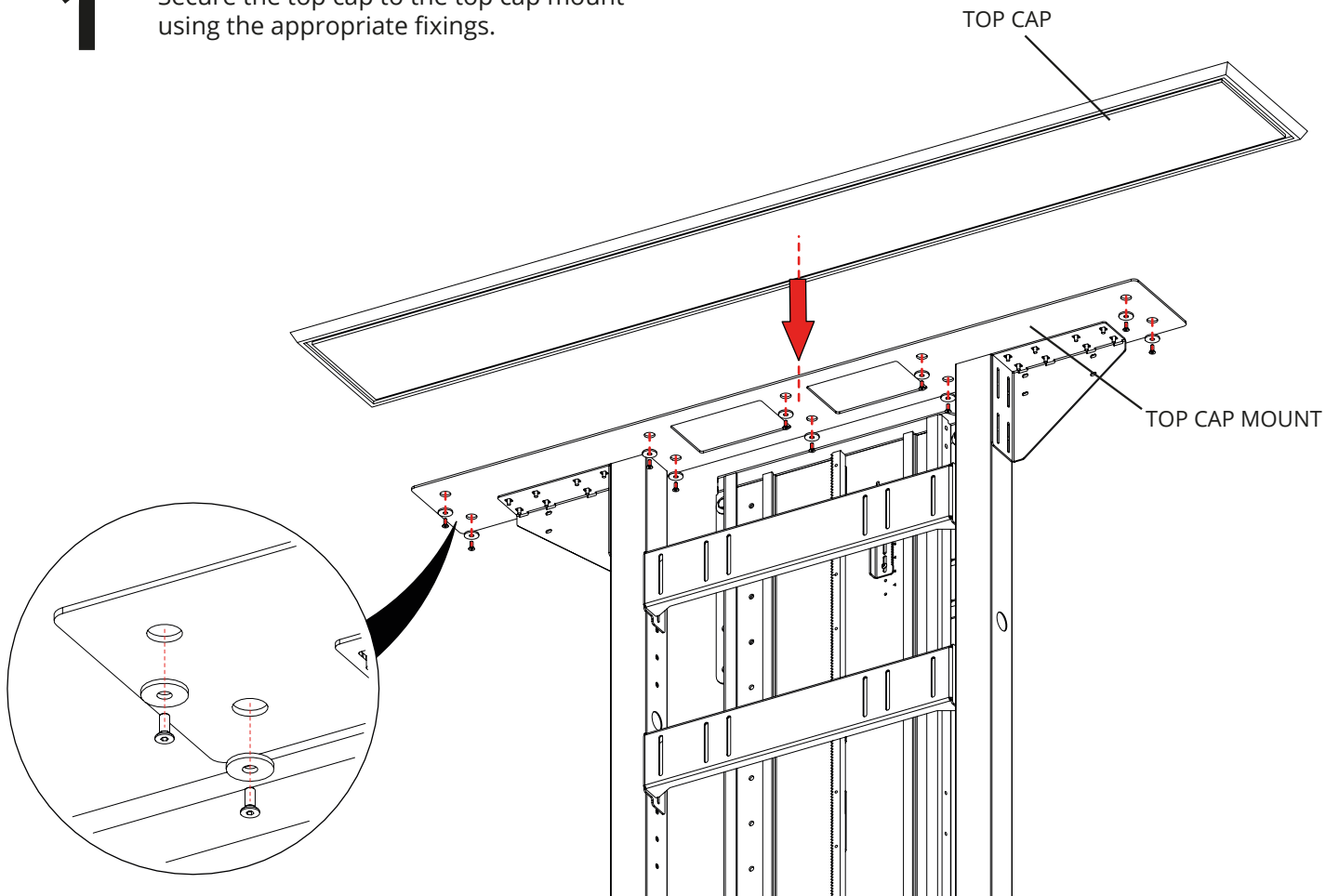

- 2** Ensure the top cap is positioned so it will not crash into the top of your flooring. Do not send the mechanism fully in till the top cap is correctly positioned and the in switch has been adjusted.

- 3** Small adjustments can be made using the oversized mounting holes.

# SWITCH ADJUSTMENTS



Only make small adjustments to top switch to avoid any collisions, which could cause damage to the mechanism or cabinetwork.

## 1

To get the base panel flush with the cabinet when up you need to adjust the top switch stop.

Loosen the bolts shown to adjust the position of the top switch stop. Use the serrated edge to make small adjustments to change its position.

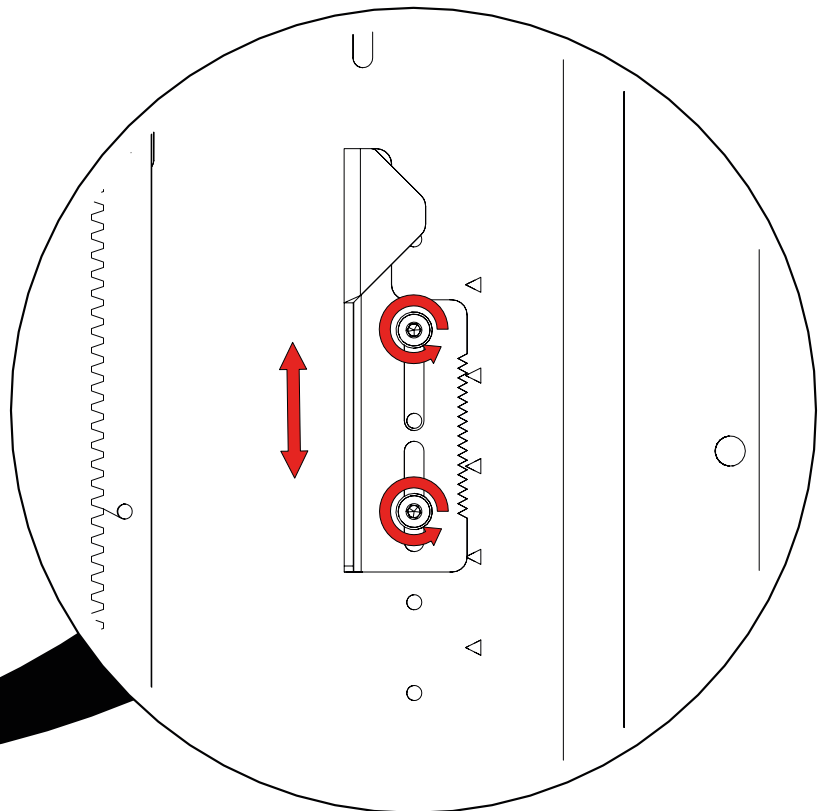
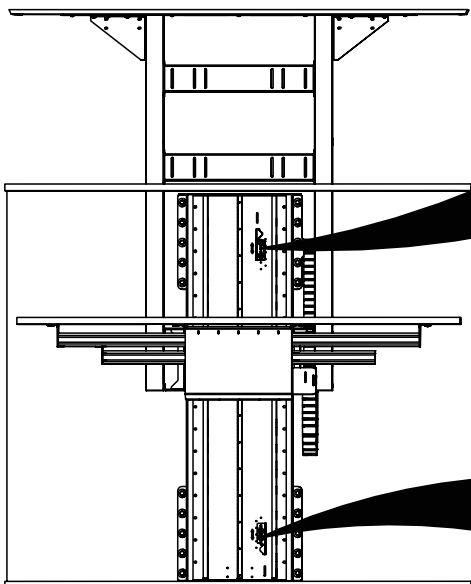

## 2

To get the top cap flush with the cabinet when down you need to adjust the bottom switch stop.

Loosen the bolts shown to adjust the position of the top switch stop. Use the serrated edge to make small adjustments to change its position.

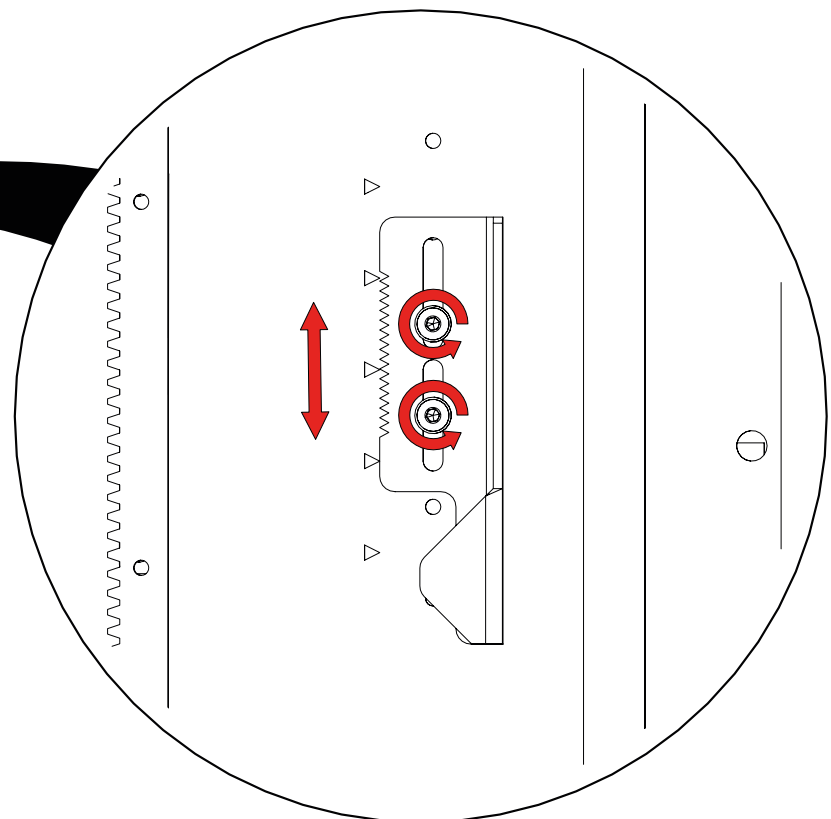

# GENERAL CONTROL

This mechanism has multiple standard control methods, each of which requires a different input method to the control box. For ease, the input sockets on the control board are labelled below.

**(Control box size and style may vary to image shown)**

## CONTROL BOX INPUTS

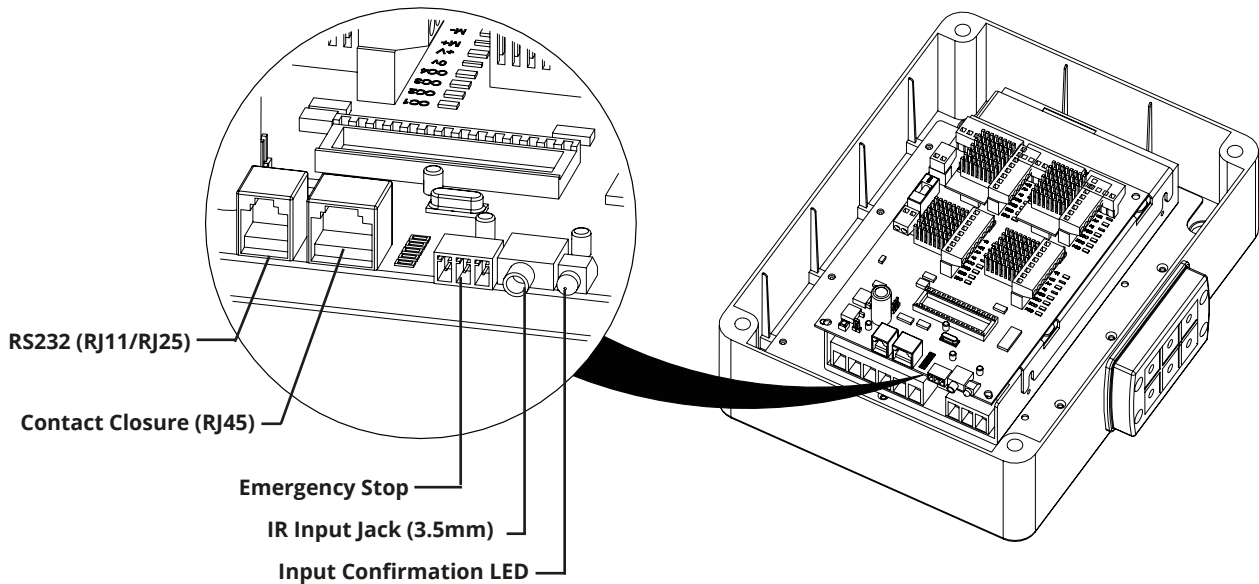

## MECHANISM EMERGENCY STOP CONNECTOR

This mechanism features an Emergency Stop Connector, which **MUST** be plugged into the control box in the connector labelled above for the mechanism to operate. If this connector is not plugged in, the Input Confirmation LED will be permanently lit. As per the red plastic tag attached to the Emergency Stop Connector (and shown below), the small loop of wire in this connector is designed to be replaced by a third party safety mechanism.



## REPLACING MECHANISM BATTERIES

The standard Future Automation Infrared (IR) remote control requires x2 AAA batteries to operate. These are provided with the mechanism in the Accessories Pack. These batteries can be replaced as per the image below.

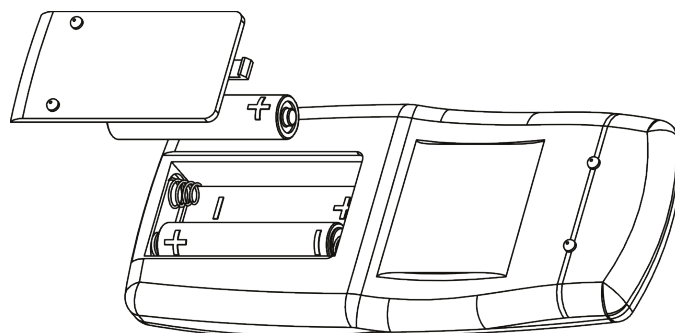

# INFRARED (IR)

This mechanism can be controlled via the supplied 14 button Infrared (IR) Remote Control, paired with the supplied Infrared (IR) lead and sensor.

The mechanism's functions can be controlled by plugging the Infrared (IR) lead and sensor into the 3.5mm IR Input Jack shown on the General Mechanism Control page.

Confirmation of Infrared (IR) input will be shown by a single flash of the large green LED located on the end of the control box.

As Infrared (IR) control works via line of site, the Infrared (IR) sensor must be directly viewable from the location the remote control is being used from.

## Infrared (IR) Remote Control Button Layout

**NOTE:** Commands involving multiple keys requires each successive key to be pressed within 2 seconds of each other.

**IN** - The mechanism is brought fully in.

**OUT** - Raises the mechanism fully out.

**STOP** - Stops the operation of the mechanism.

**HOME** - Raises the mechanism fully out. .

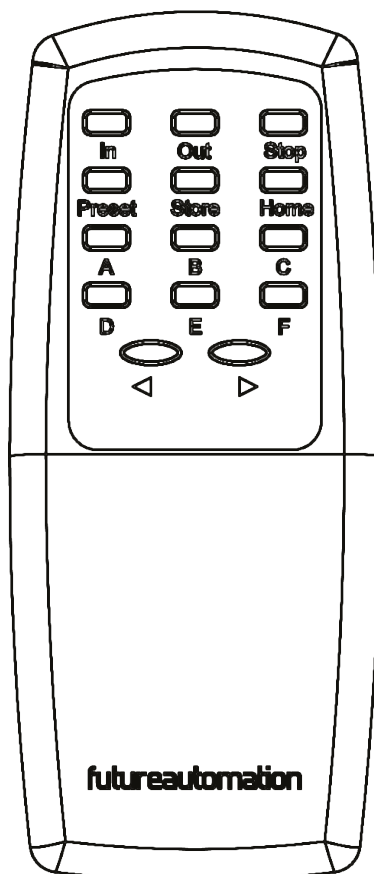

### IMPORTANT

Only buttons indicated above are functional with the product. Any other button press will STOP the mechanism.

# CONTACT CLOSURE

This Mechanism can be controlled via Contact Closure, utilising the 8 Pin RJ45 Connector attached to a length of CAT5 (Type 568A or 568B) cable.

The mechanism's functions can be controlled by plugging this into the RJ45 port on the mechanism control board, then shorting pins 1-8 on this connector as shown in the Contact Closure Input Table below.

Confirmation of Contact Closure input will be shown by a single flash of the large green LED located on the end of the control box, as well as illumination of the corresponding Contact Closure LED on the printed circuit board as shown below.

**RJ45 Pin Layout**

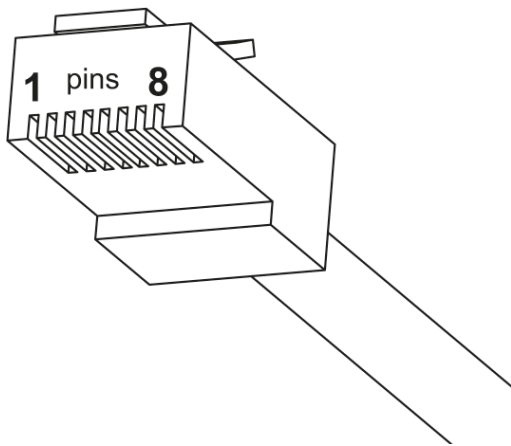

**Contact Closure LED Layout**

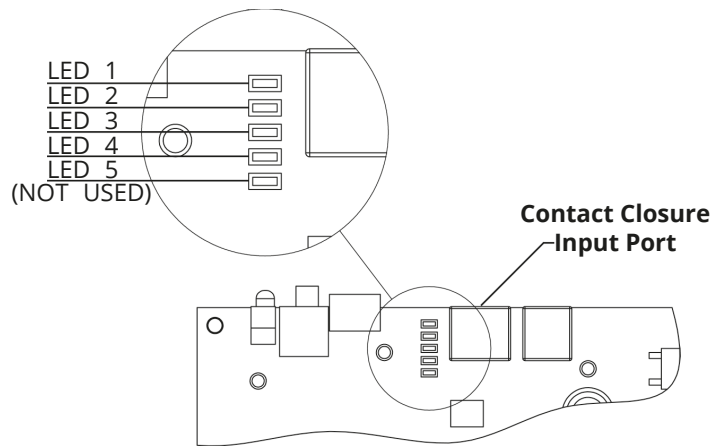

**Contact Closure Input Table**

PIN	DESCRIPTION	ACTION
1	12V SUPPLY	12V SUPPLY - CURRENT LIMITED
2		
3	GROUND	GROUND
4		
5	DEVICE LEFT / STOP	MOMENTARY SHORT TO GROUND (PIN 3), MAKES DEVICE MOVE LEFT OR STOP IF MOVING.
6	DEVICE RIGHT / STOP	MOMENTARY SHORT TO GROUND (PIN 3), WILL MAKE DEVICE MOVE RIGHT OR STOP IF MOVING.
7	DEVICE HOME / STOP	MOMENTARY SHORT TO GROUND (PIN 3), WILL MAKE DEVICE GO HOME OR STOP IF MOVING.
8	DEVICE IN / STOP	MOMENTARY SHORT TO GROUND (PIN 3), WILL MAKE DEVICE GO IN OR STOP IF MOVING.

WIRE/CABLE TYPE		LED INDICATOR
568A	568B	
W/G	W/O	
G	O	
W/O	W/G	
B	B	
W/B	W/B	LED 4
O	G	LED 3
W/BR	W/BR	LED 2
BR	BR	LED 1



# RS232 CONTROL

This Mechanism can be controlled via RS232, utilising a 6 Pin RJ11/RJ25 connector OR 9 Pin Serial connector attached to a length of 6 core cable.

The mechanism's functions can be controlled by plugging this into the RJ11/RJ25 port on the mechanism control box, then inputting the RS232 commands shown in the RS232 Input Table below.

Confirmation of Contact Closure input will be shown by a single flash of the large green LED located on the end of the control box.

## RJ11/RJ25 PIN LAYOUT

- PIN 1: RX**
- PIN 6: TX**
- PIN 3 & 4: GROUND**

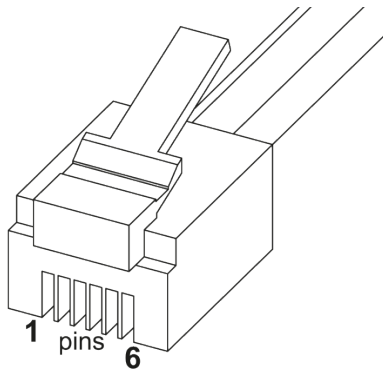

## SERIAL PIN LAYOUT

- PIN 2: RX**
- PIN 3: TX**
- PIN 5: GROUND**

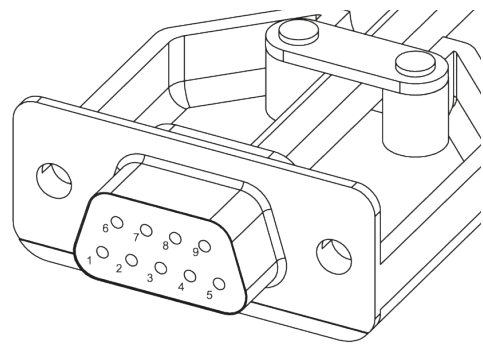

## RS232 PROGRAMMING DETAILS

Baud Rate: 9600

Stop Bit: 1

Parity: None

Databits: 8

RJ11/RJ25	Func.	9 PIN Serial	Colour
PIN 1	TX-RX	PIN 2	Blue
PIN 3	GROUND	PIN 5	Green
PIN 4	GROUND	PIN 5	Red
PIN 6	RX-TX	PIN 3	White

## RS232 INPUT TABLE

**IMPORTANT - Ensure all protocols are entered exactly as written below, including Carriage Return (ENTER / ASCII 13)**

Protocol	Action
fa_in Carriage Return (Enter / ASCII 13)	Device IN
fa_out Carriage Return (Enter / ASCII 13)	Device OUT no movement to swivel
fa_stop Carriage Return (Enter / ASCII 13)	Device STOP (At any position)
fa_home Carriage Return (Enter / ASCII 13)	Device UP and swivel parallel
fa_left Carriage Return (Enter / ASCII 13)	Device UP and rotation to LEFT limit
fa_right Carriage Return (Enter / ASCII 13)	Device UP and rotation to RIGHT limit
fa_a Carriage Return (Enter / ASCII 13)	Device OUT and preset position A
fa_b Carriage Return (Enter / ASCII 13)	Device OUT and preset position B
fa_c Carriage Return (Enter / ASCII 13)	Device OUT and preset position C
fa_preset Carriage Return (Enter / ASCII 13)	Device UP and preset position "PRESET"







#### **EUROPEAN OFFICE**

**Address:**  
Unit 6-8  
Brunel Road  
Bedford  
Bedfordshire  
MK41 9TG

**Phone:** +44 (0) 1438 833577  
**Email:** [info@futureautomation.co.uk](mailto:info@futureautomation.co.uk)

**Office Hours:**  
Mon - Fri 8:00 to 17:30 GMT  
Saturday & Sunday - Closed

#### **NORTH AMERICAN OFFICE**

**Address:**  
Enterprise Park  
127 Venture Drive  
Dover  
NH  
03820

**Phone:** +1 (603) 742 9181  
**Email:** [info@futureautomation.net](mailto:info@futureautomation.net)

**Office Hours:**  
Mon - Fri 7:00 to 17:00 EST  
Saturday & Sunday - Closed